

## POOL PROGRAM

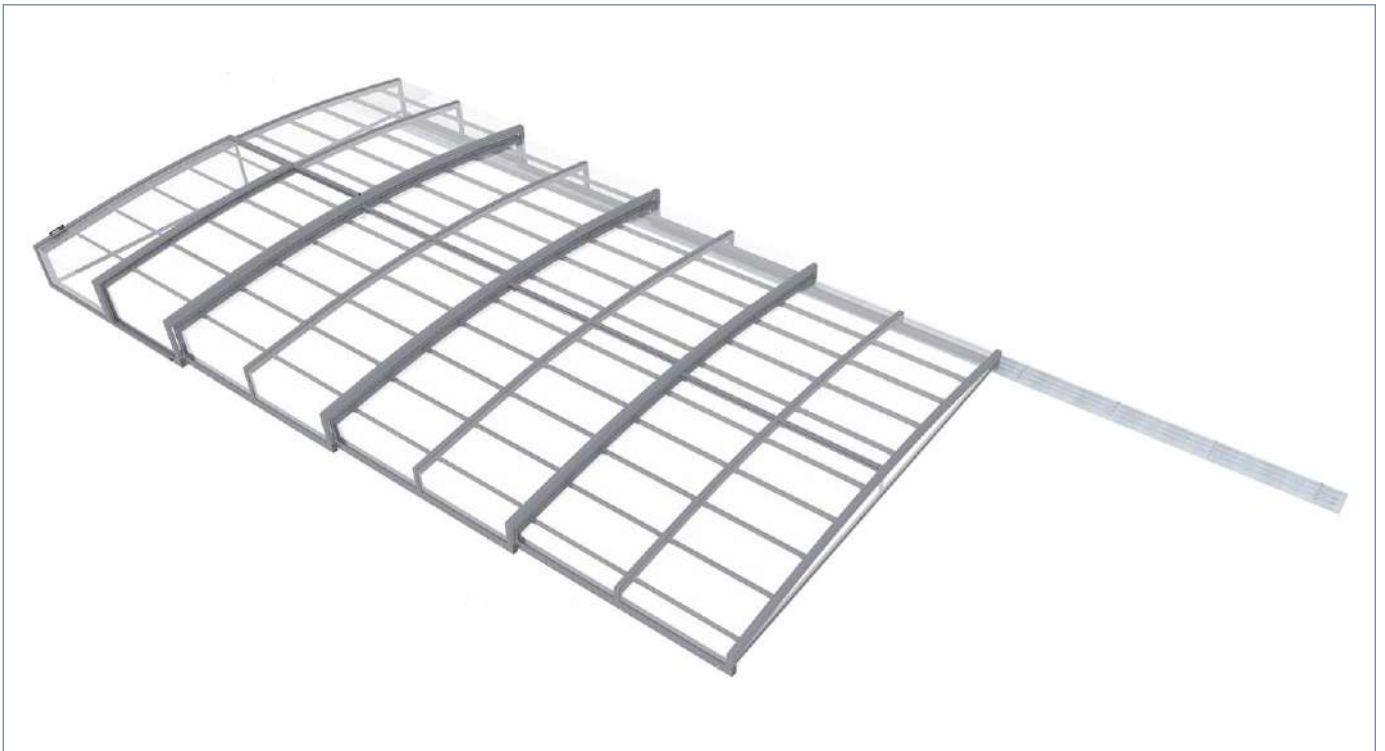

### ASSEMBLING INSTRUCTIONS FOR ENCLOSURES

## PARADE / PARADE LOW



Distributor:  
**ALUKOV a.s.**, Orel 18, 538 21 Slatiňany  
Tel.: +420 469 681 488, Mobil: +420 731 623 475  
E-mail: [info@alukov.cz](mailto:info@alukov.cz)  
[www.alukov.cz](http://www.alukov.cz), [www.enclosure.guru](http://www.enclosure.guru)

99.MP.0074.EN  
revision: 18.07. 2024

**IMPORTANT**

- Please read these instructions carefully before you start to assemble your enclosure.
- Please carry out the steps in the order set out in these instructions.
- Keep these instructions in a safe place for future reference.
- Prior to installation be sure to check your local building and zoning requirements.

**SAFETY ADVICE**

- Use of work gloves and safety glasses during assembly is required.
- Do not attempt to assemble the enclosure in windy or wet conditions.
- Do not touch overhead power cables (if any) with the aluminum profiles.
- Always wear shoes and safety goggles when working with extruded aluminum.
- Dispose of all plastic bags safely - keep them out of reach of small children.
- The enclosure must be positioned and attached on a flat level surface.
- Do not lean against or push the enclosure during assembly.
- Keep children away from the assembly area.
- Do not position your enclosure in an area exposed to excessive wind or overhead tree limbs.
- Do not attempt to assemble the enclosure, if you are tired, have taken drugs or alcohol or if you are prone to dizzy spells.
- If using a step ladder or power tools, ensure that you follow the manufacturer's safety advice.

**TRACK INSTALLATION**

A flat, level surface is required; any of the following is acceptable:

- 3.5" thick foundation of reinforced concrete
- Pavers set in Concrete
- Wood/composite decking

**TOOLS AND EQUIPMENT REQUIRED**

- more informations about recommended tools are in this assembling procedure

**CLEANING**

Polycarbonate panels can easily be cleaned by hosing down with cold clean water or with a soft cloth made from 100% cotton using a mild dish detergent solution and rinsing with cold water.

**DO NOT use acetone, abrasive cleaners or other special detergents to clean the panels. This will void warranty!**

**IMMEDIATE REMOVAL OF PROTECTION SHEETS FROM PANELS**

The polyethylene masking (plastic sheets/foil) must be removed immediately from the panels during or immediately after installation. The polyethylene masking covers the panels to protect them during handling, shipping, storage, and installation. If it is removed at a later time, it may be very difficult if not impossible to remove as it will stick to the panel. In hot climates, even 24 hours after the installation is completed it may be too late to remove.

**COPYRIGHT AND INDUSTRIAL PROPERTY RIGHTS**

The producer reserves the options to make technical changes to its products.

The profiles are the intellectual property of the company Alukov a.s. and are registered as an industrial design of the European Community.

Alukov®

ITEM  
**TRANSPORT**

---

ASSEMBLING INSTRUCTIONS FOR ENCLOSURES

## TRANSPORT OF THE ENCLOSURE IN WOODEN TRANSPORT BOX

This wooden transport box must be secured on a truck to avoid movement, deformation and damage of the enclosure during the transport to a client and safer for loading and unloading of the enclosure too.

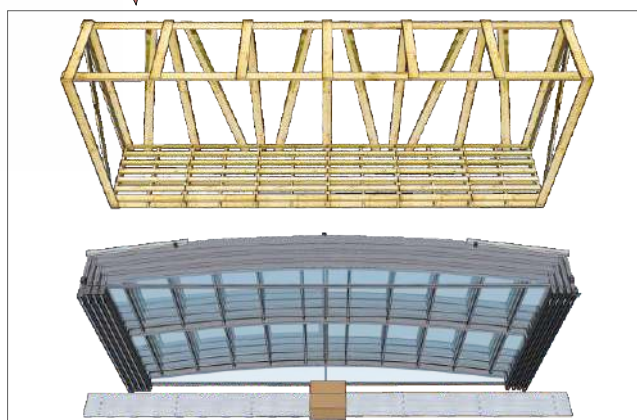
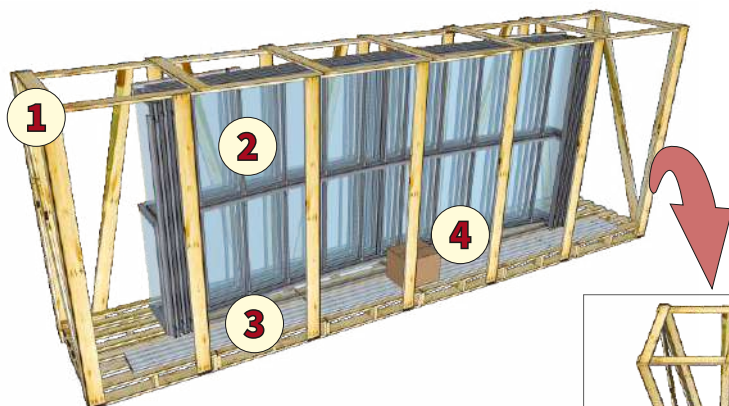

<b>01</b>	Wooden transport box
<b>02</b>	Segments ( package )
<b>03</b>	Rails ( package )
<b>04</b>	Package ( contents for completion of assembly )

## TRANSPORT OF THE ENCLOSURE ON PLATFORM OF THE TRUCK

The enclosure must be secured on platform of truck to avoid movement, deformation and damage of the enclosure during the transport to a client. However, loading and unloading the enclosure in this case is time and physically more demanding than in the case of a wooden box.



Alukov®

ITEM  
**INTRODUCTION**

---

ASSEMBLING INSTRUCTIONS FOR ENCLOSURES

## ENCLOSURE - MAIN PARTS

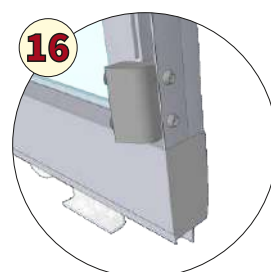
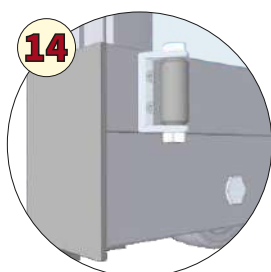
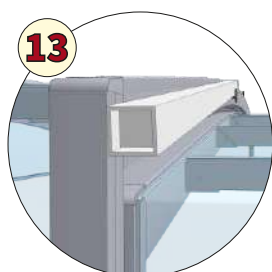
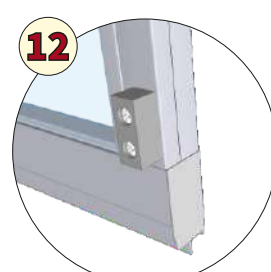
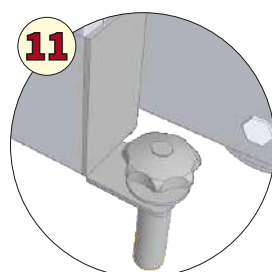
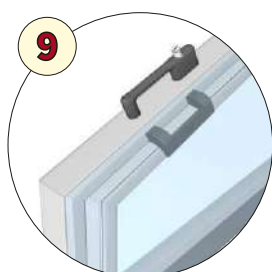
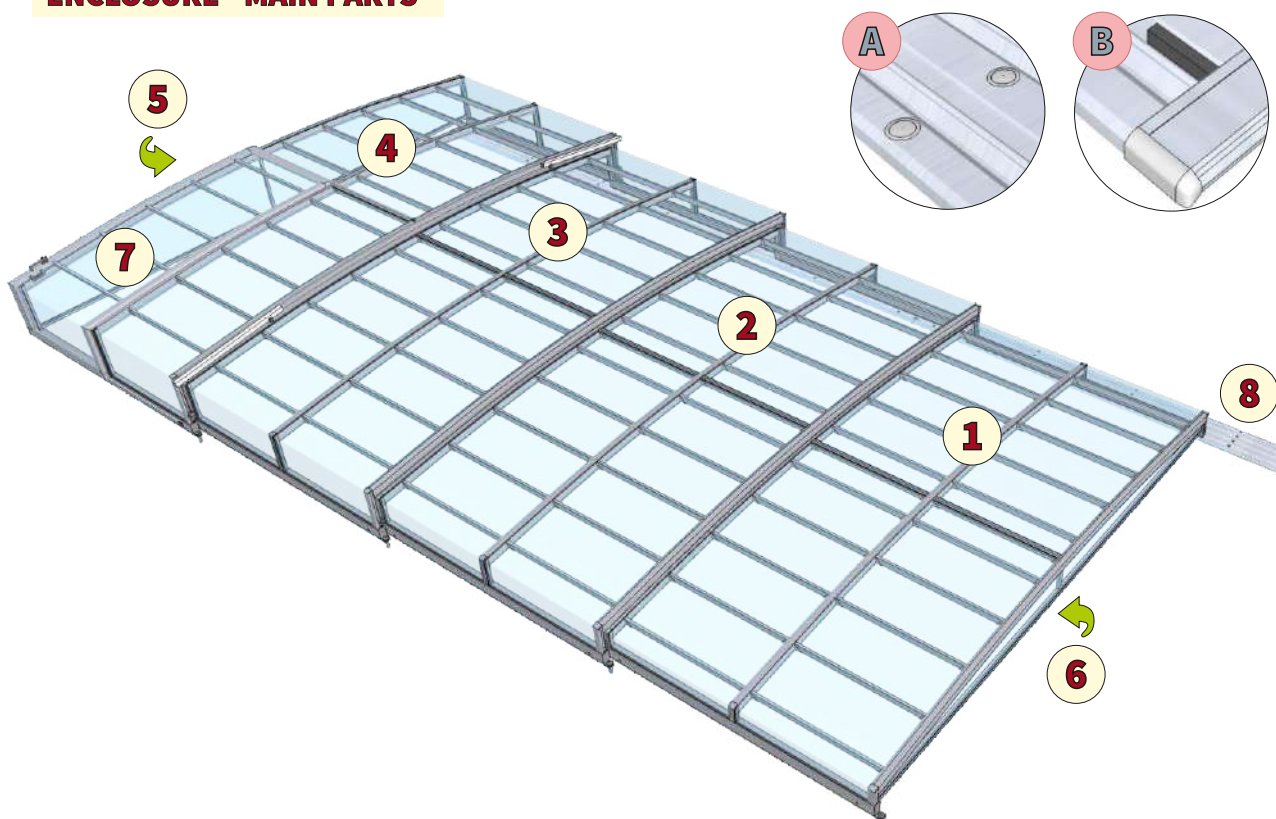

<b>01</b>	Segment nr.1 ( smallest )
<b>02</b>	Segment nr.2
<b>03</b>	Segment nr.3
<b>04</b>	Segment nr.4 ( largest )
<b>05</b>	Large detachabled face
<b>06</b>	Small detachabled face

<b>07</b>	Lateral door ( on large segment )
<b>08</b>	Rail
<b>09</b>	Handle of lateral door
<b>10</b>	Bracket on outer side of travel profile
<b>11</b>	Side arrestment for descent segments
<b>12</b>	Outer stopper for descent segment

<b>13</b>	Handle for moving with enclosure
<b>14</b>	Roller on inner side of travel profile
<b>15</b>	Arrestment of segment with lock + stopper
<b>16</b>	Inner stopper for descent segment
<b>A</b>	Plastic cap for rails
<b>B</b>	End of rail + plastic backstop for travel

## **THE DEPENDENT SEGMENTS**

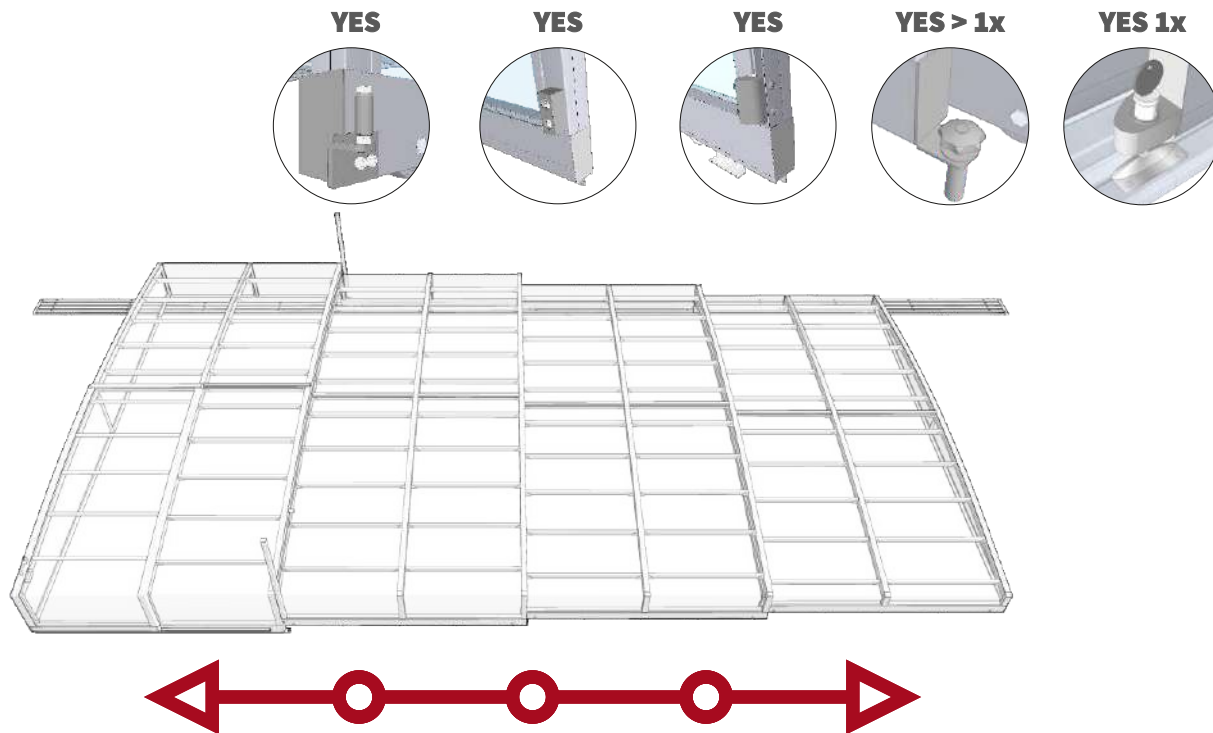

## **THE INDEPENDENT SEGMENTS**

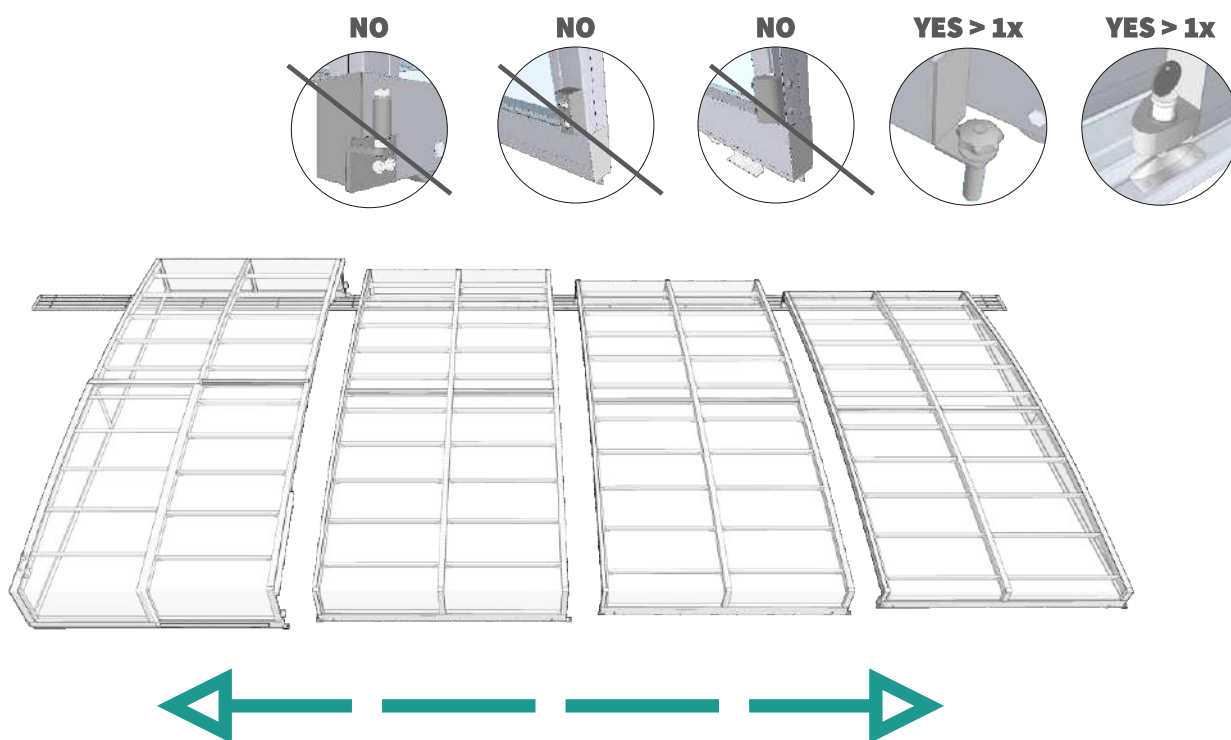

## **THE DEPENDENT SEGMENTS**

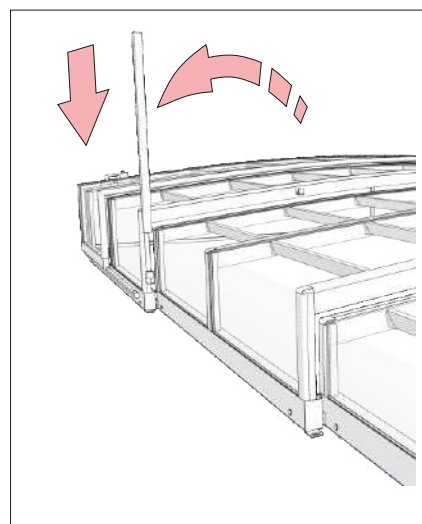
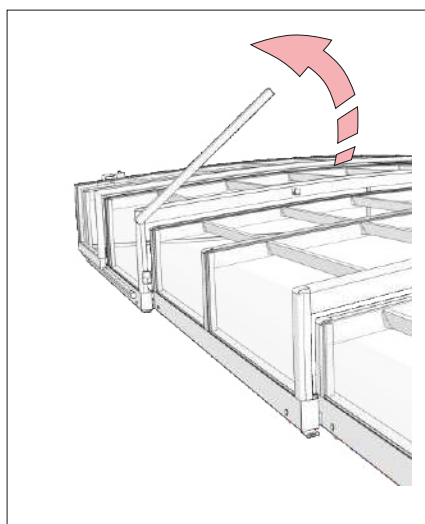
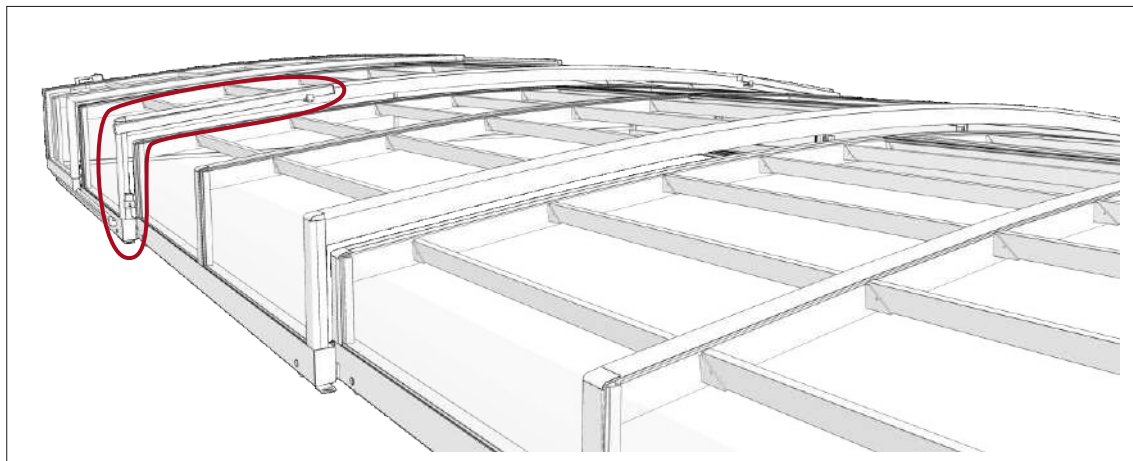

**THE HANDLE IS ON THE LARGEST SEGMENT ONLY - THE SUPPORT FOR EASILY SHIFTING WITH SEGMENTS AT ONCE !**

## **THE INDEPENDENT SEGMENTS**

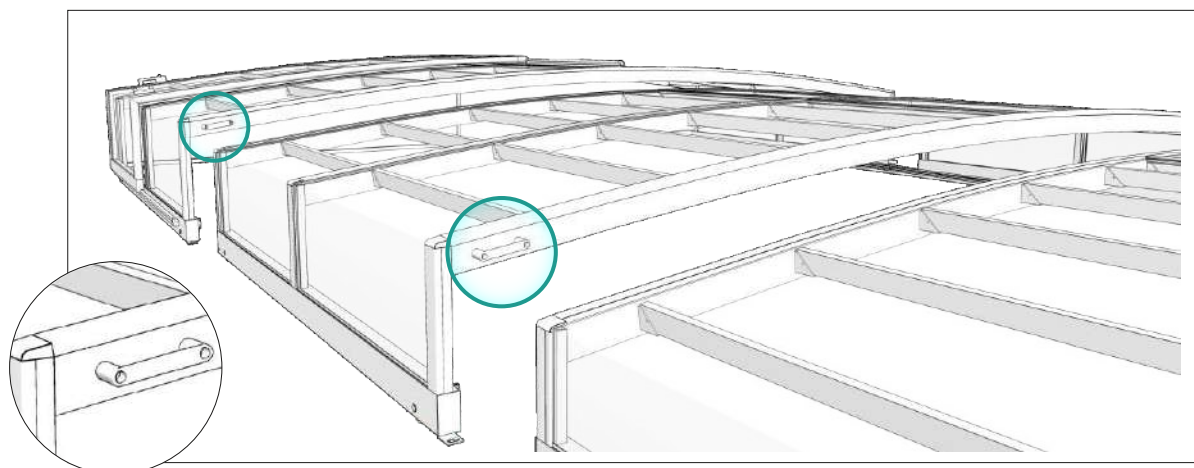

**HANDLE IS ON EACH SEGMENT - THE SUPPORT FOR EASILY SHIFTING WITH INDEPEDENT SEGMENT !**

## **IDENTIFICATION OF THE SELECTED FIX MATERIAL FOR ASSEMBLY**

### **SCREW**

<i>POZ</i>	<i>METRIC DIMENSION</i>	<i>HEAD SHAPE</i>	<i>USE FOR JOINT OF THE ...</i>
<b>A1</b>	M6 x 45 mm	IMBUS	fix the brackets between segments
<b>B1</b>	6,3 x 50 mm	PAN	fix the connection - outer stopper

### **NUT**

<i>POZ</i>	<i>METRIC DIMENSION</i>	<i>TYPE</i>	<i>USE FOR JOINT OF THE ...</i>
<b>A2</b>	M6	SAFETY	fix the brackets between segments

### **RIVET**

<i>POZ</i>	<i>METRIC DIMENSION</i>	<i>TYPE</i>	<i>USE FOR JOINT OF THE ...</i>
<b>A3</b>	4 x 10 mm		stopper for rails AZURE, connector
	4 x 10 mm		plastic backstop, end of rails
<b>B3</b>	4 x 16 mm		base of the face arrestment
	4 x 16 mm - black		base of the side arrestment

### **PLASTIC CAP**

<i>POZ</i>	<i>METRIC DIMENSION</i>	<i>TYPE</i>	<i>USE FOR JOINT OF THE ...</i>
<b>A4</b>	D 15 mm	colour per rail	cover of predrilling hole in ground rails
<b>B4</b>	M6	BLACK	cover of nuts M6

### **FIX THE RAILS TO GROUND**

**( type of the fix material depend on basement type )**

<i>POZ</i>	<i>METRIC DIMENSION</i>	<i>HEAD SHAPE</i>	<i>USE FOR JOINT OF THE ...</i>
<b>A5</b>	6,3 x 32 mm	PAN	fix to wooden - standard
<b>B5</b>	8 x 60 mm	raw plug	fix to concrete - standard

Alukov®

ITEM

# PREPARE JOBSITE

---

ASSEMBLING INSTRUCTIONS FOR ENCLOSURES

## TOOLS FOR ASSEMBLY - RECOMMENDED

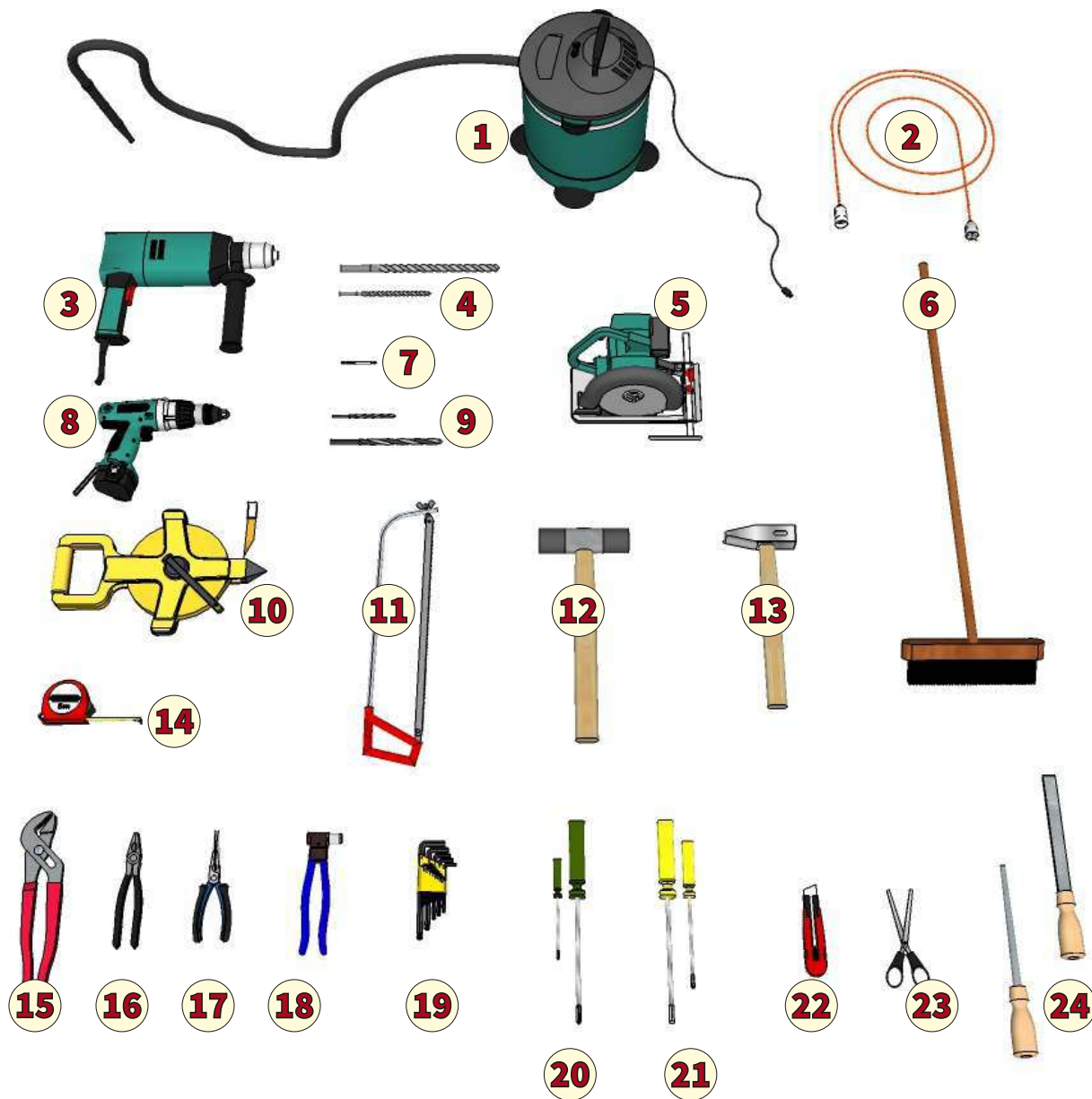

<b>01</b>	Vacuum cleaner
<b>02</b>	Cord - extension set
<b>03</b>	Pneumatic hammer
<b>04</b>	Drill to concrete ( Ø 8mm; Ø 15mm )

<b>09</b>	Drill ( Ø 4mm; Ø 5mm; Ø 6,2mm; Ø 7mm )
<b>10</b>	Steel band
<b>11</b>	Metal saw
<b>12</b>	Rubber soft hammer

<b>17</b>	Small flat pliers
<b>18</b>	Rivet pliers
<b>19</b>	Set - socket wrench
<b>20</b>	Screwdriver - flat ( small / large )

<b>05</b>	Circular saw
<b>06</b>	Dust - brush
<b>07</b>	Screwdriver bits
<b>08</b>	Accumulator screwdriver

<b>13</b>	Hammer
<b>14</b>	Measuring tape
<b>15</b>	Tongs
<b>16</b>	Flat pliers

<b>21</b>	Screwdriver - cross ( small / large )
<b>22</b>	Knife
<b>23</b>	Scissors for edit of rubber sealing
<b>24</b>	File ( round / flat )

## PREPARING THE ASSEMBLY PLACE

THESE SEVERAL BASIC STEPS GOING TO FOLLOW BEFORE ASSEMBLING PROCEDURE

### ELECTRICAL SUPPLY CONNECTION



### ENSURE AN ACCESS TO A POOL

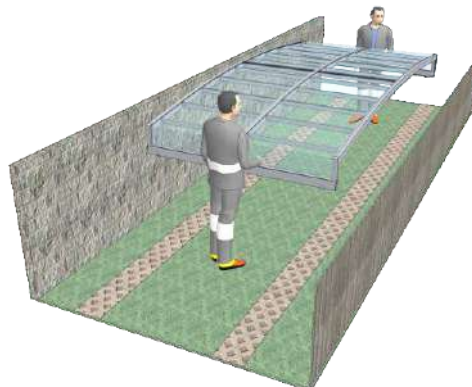

Manipulation by minimal two persons (bringing the other segments to the pool area) and find the simplest and easiest way to the pool area!

### CLARIFY A POSITION OF THE ENCLOSURE - LARGEST SEGMENT - PARKZONE

POSITION OF THE LARGEST SEGMENT / COVER CLOSED

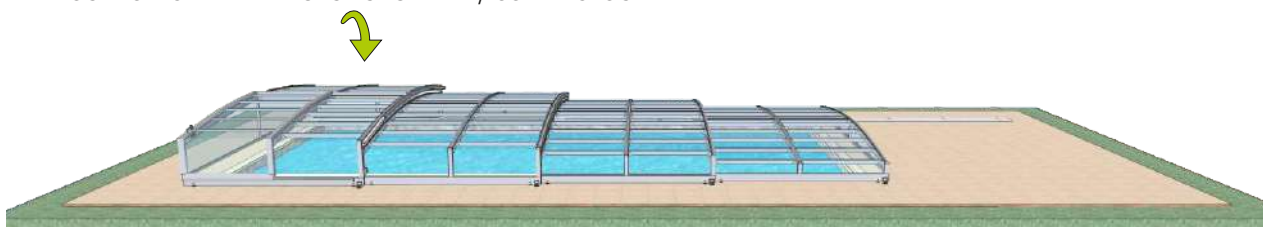

DIRECTION OF MOVEMENT OF THE ENCLOSURE

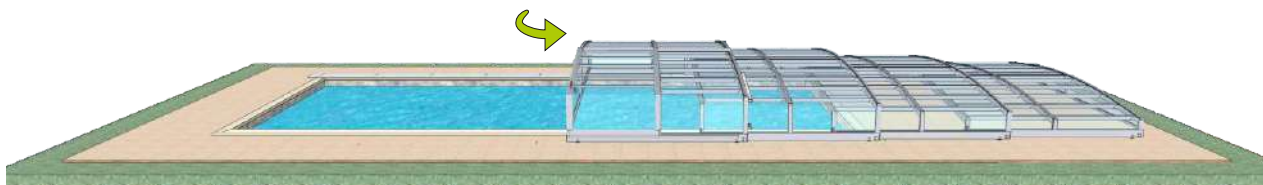

USUALLY PARKZONE - PARKING POSITION OF THE ALL SEGMENTS TOGETHER



This informations may not be corresponding with technical drawing / assembling documentation.

## MINIMAL TIME FOR ASSEMBLY

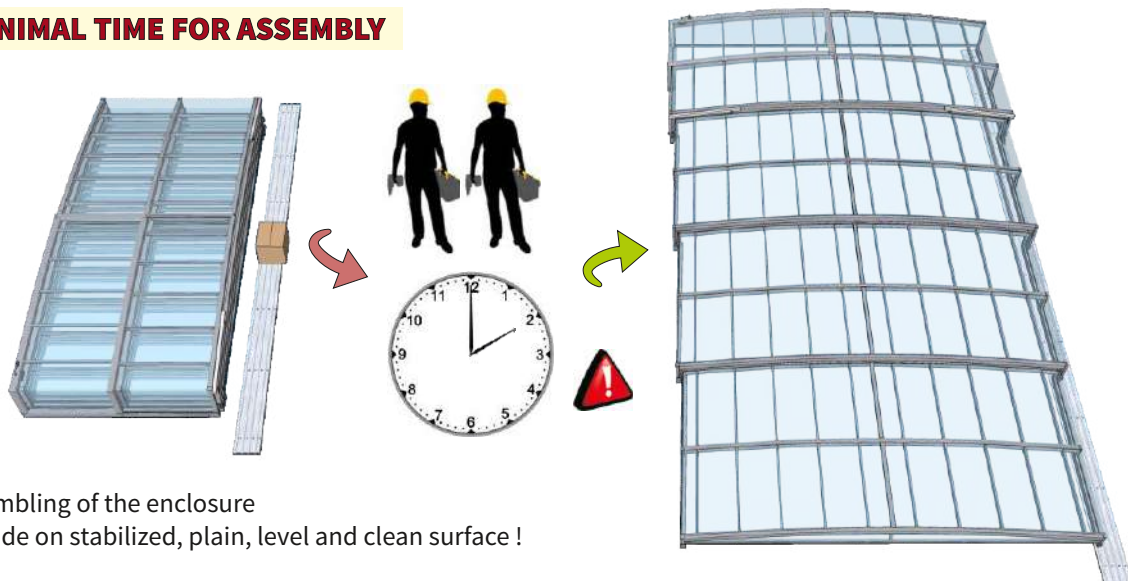

Assembling of the enclosure is made on stabilized, plain, level and clean surface !

Be careful while manipulate with other segments to avoid damage, deformation and cratching and respect to weight of the every segment assure sufficient number of people for manipulation with the segment.

## CLEANING THE ASSEMBLY PLACE

 Clean the surface around the pool, especially the places, where the rail will be fixed

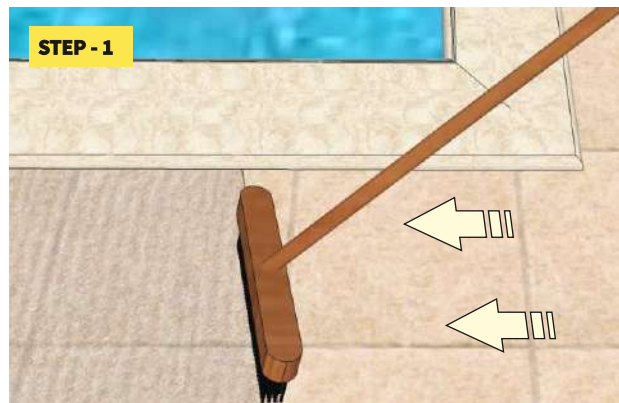

## PREPARING OF THE RAILS ON THE ASSEMBLY PLACE

 Prepare the rail for connection the parts of rail along total length of the rail

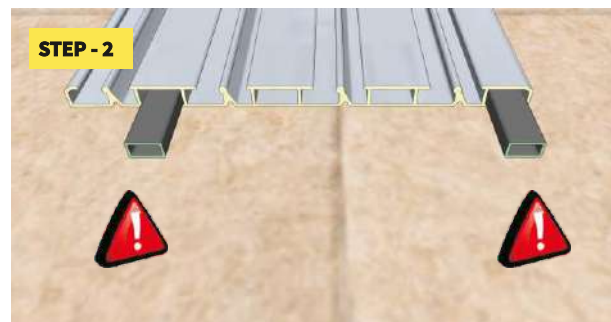
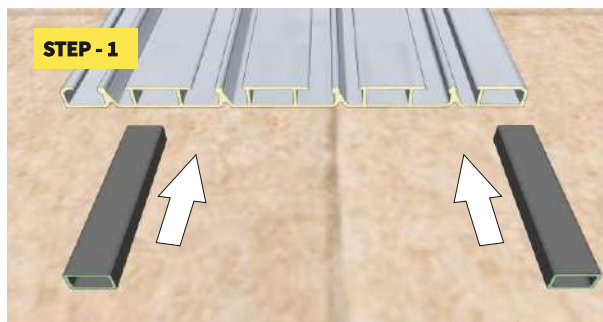

Put the sole connector into sole chamber of the rail, so that connector will be protrude with one half from total length of connector.

## PREPARING OF THE RAILS ON THE ASSEMBLY PLACE

### STEP - 3

#### INFORMATION



**EACH CONNECTOR** must be protrude with one half from total length of connector.  
Rivet the connection - the same way for left and right rail.

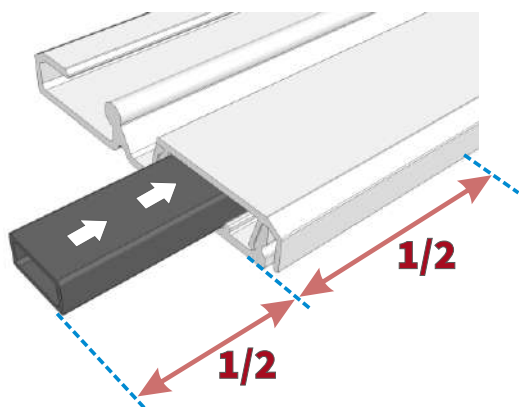

#### FIX MATERIAL

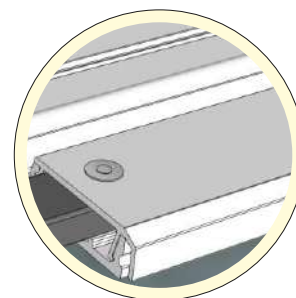

**RIVET 4x10 mm A2**  
( 1 CONNECTOR = 1 pce for join of the connector to rail )

## POSITION OF CONNECTORS FOR MONOLITHIC RAILS

### STEP - 4

#### THE MONOLITHIC RAIL AZURE - RECCOMENDED POSITION OF CONNECTOR

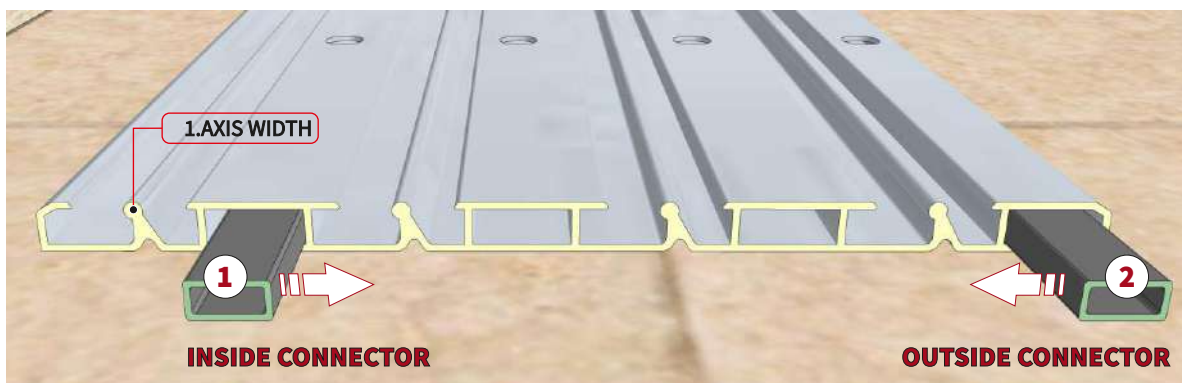
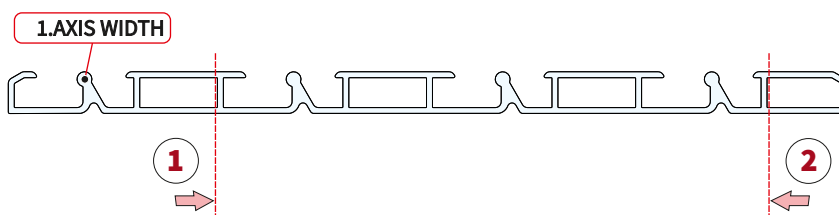

## PACKAGE - BASIC CONTENTS

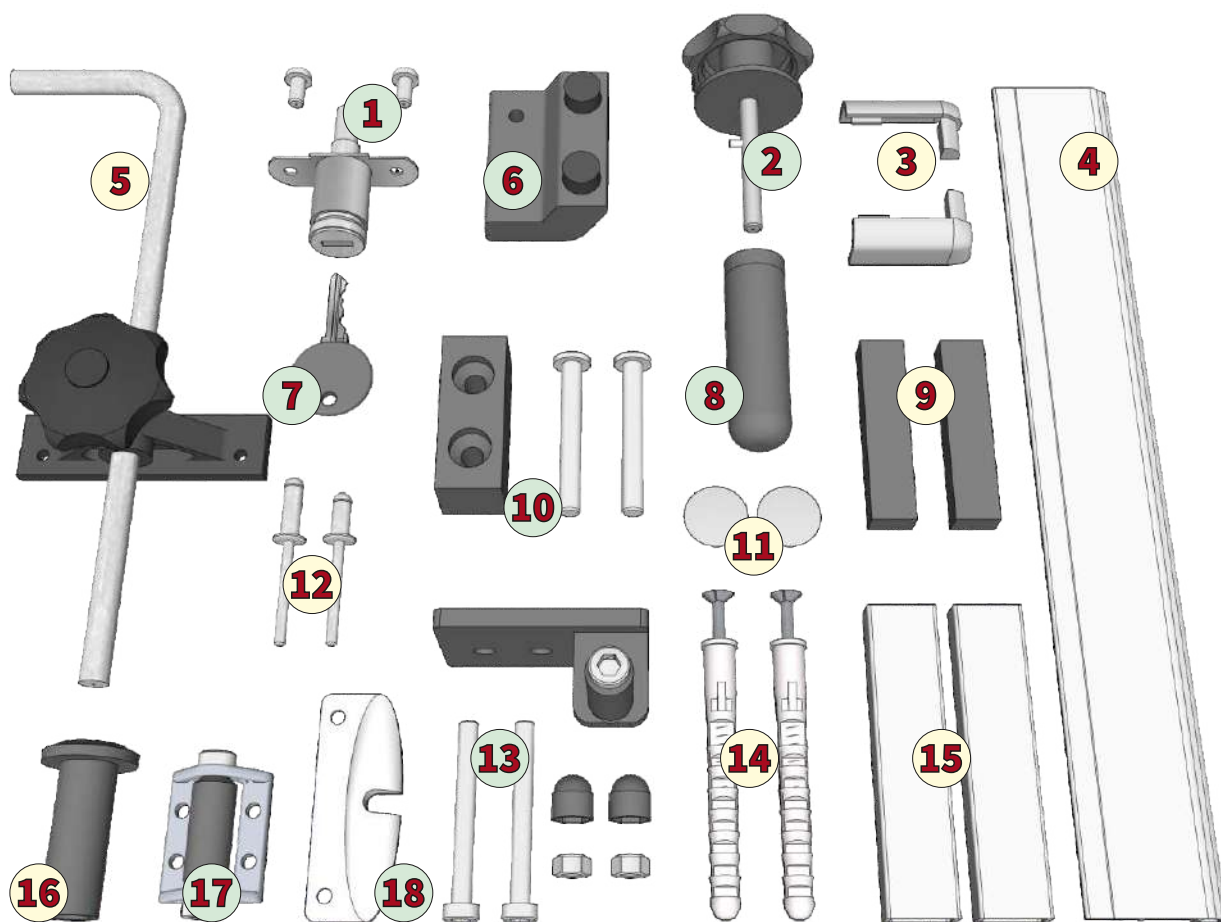
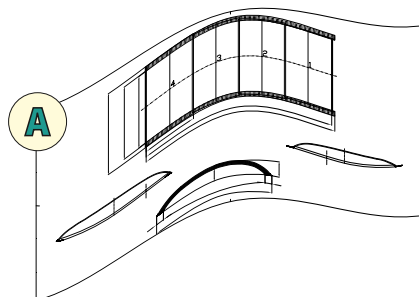

**X** \* selection the components according to dependent or independent segments

<b>A</b>	Technical drawing of enclosure
<b>01</b>	Arrestment lock for segment
<b>02</b>	Side arrestment for segment - pin
<b>03</b>	Plastic cap for end of rail
<b>04</b>	End of rail
<b>05</b>	Face arrestment - large/small face
<b>06</b>	Connection between segments - inner type

<b>07</b>	Key fo arrestment lock
<b>08</b>	Side arrestment - insert for pavement
<b>09</b>	Plastic backstop for travel
<b>10</b>	Connection between segments - outer type
<b>11</b>	Plastic cap for ground rails
<b>12</b>	Rivets

<b>13</b>	Bracket between segments
<b>14</b>	Raw-plugs
<b>15</b>	Connection for rail
<b>16</b>	Insert for pavement - face arrestment
<b>17</b>	Roll between segments
<b>18</b>	Stopper ( arrestment of segment )

## RIVET THE CONNECTION INTO ONE RAIL



**EACH CONNECTOR MUST BE PROTRUDE WITH ONE HALF FROM TOTAL LENGTH OF CONNECTOR.**

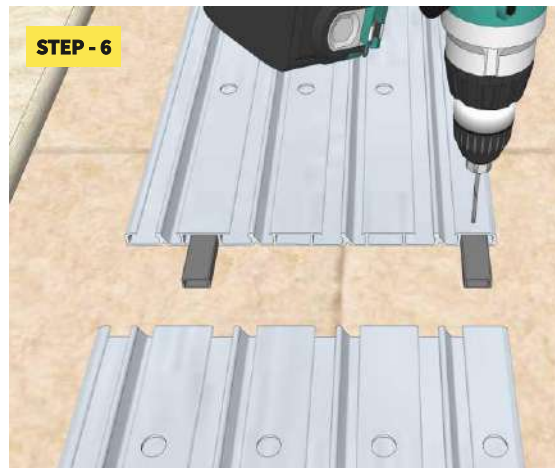

**KEEP RECCOMENDED POSITION OF CONNECTOR, DRILLING HOLE FOR RIVET THROUGH RAIL.**

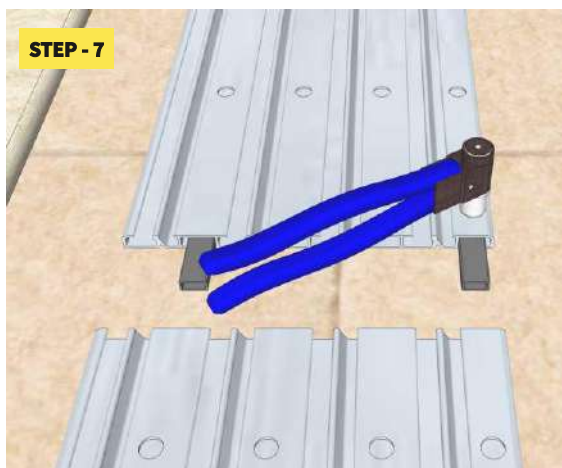

**RIVET OF TWO CONNECTORS INTO ONE PART OF RAIL**



**TWO CONNECTORS FIX IN ONE PART OF RAIL ONLY**

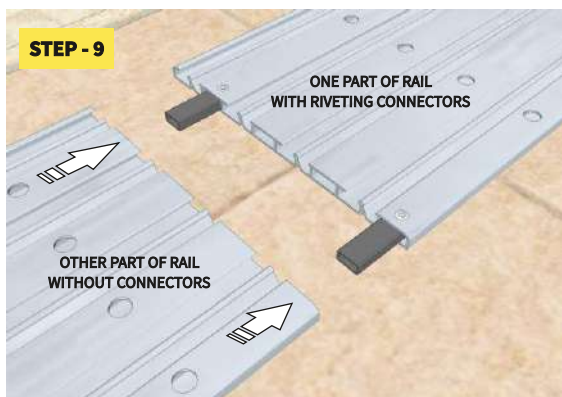

**CONNECTING THE PART OF RAIL ALONG TOTAL LENGHT**

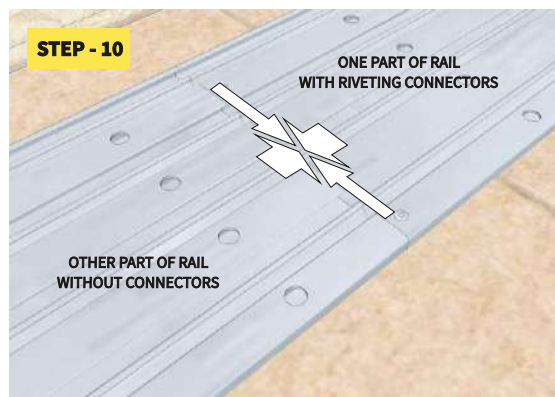

**CONNECTING OF THE SEVERAL PARTS OF RAIL ALONG TOTAL LENGHT**

Alukov®

ITEM  
**MEASUREMENT**  
**THE LEADING LINES**

---

ASSEMBLING INSTRUCTIONS FOR ENCLOSURES

## LEGEND FOR TECHNICAL DOCUMENTATION / MEASUREMENT

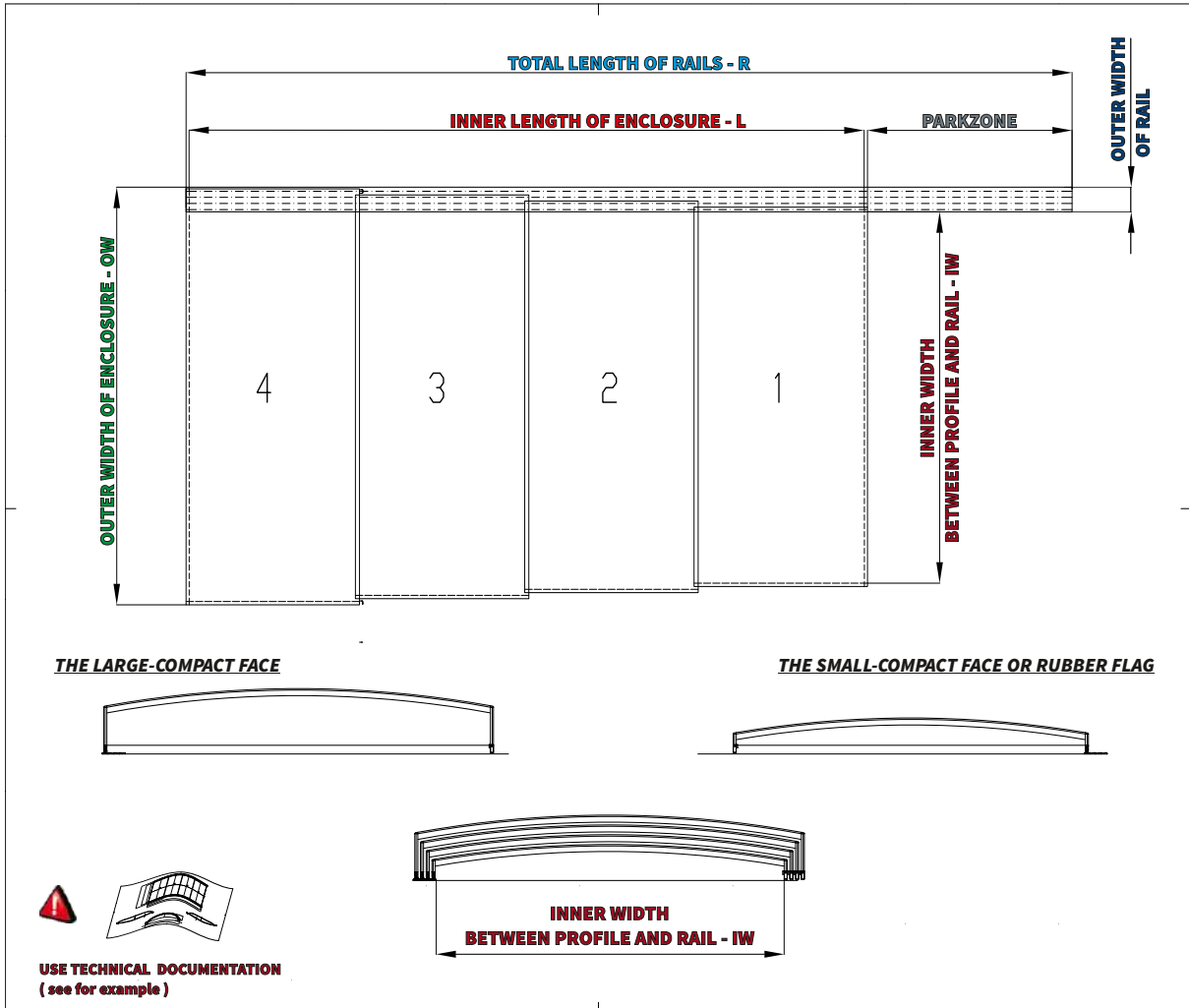

### DIMENSIONS OF POOL - P

These outer dimensions of pool are for assessment of minimal distance from outer edge of the pool.

### INNER LENGTH OF ENCLOSURE - L

This inner length is length between both faces.  
(Sum of length of the pool + minimal sufficient distance from the outer edge of the pool)

### INNER WIDTH BETWEEN PROFILE AND RAIL - IW

This inner width of enclosure is sum of width of the pool with minimal sufficient distance from the outer edge of the pool.

### DISTANCE - D

This distance is space between the outer edge of the pool and inner edge of rail or profile and compact faces of enclosure too.

### TOTAL LENGTH OF RAILS - R

This total length of rails is longer than is length of enclosure.

### PARKZONE / EXTENSION RAIL

This extension is minimal for necessary arrestment of segments or maximal for parkzone of all segments out of the pool.



**After every movement or adjustment the rails again check and measure these dimensions IW, OW, L, R, D !**



## 1-TH STEP OF MEASUREMENT CENTRE PER WIDTH DIMENSIONS

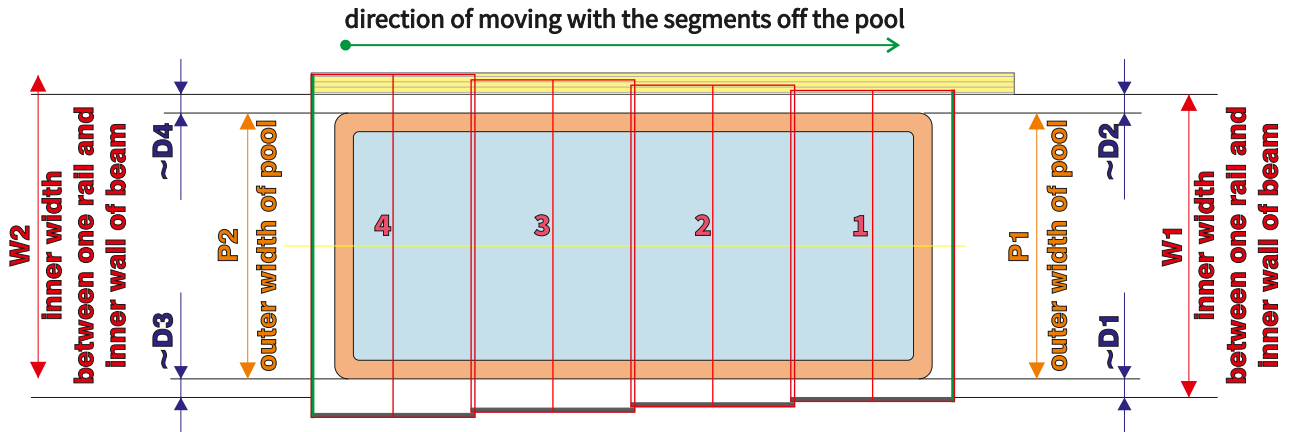
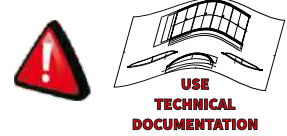

**(W2 - P2) : 2 = D3**  
**(W2 - P2) : 2 = D4**

**D3 = D4**

WHEN DIMENSIONING,  
BASE ON THE DIMENSIONS OF THE SMALLEST SEGMENT

**(W1 - P1) : 2 = D1**  
**(W1 - P1) : 2 = D2**

**D1 = D2**

## BASIC LAYOUT FOR CORRECT MEASUREMENT - ACCURATE CHECK OF WIDTH

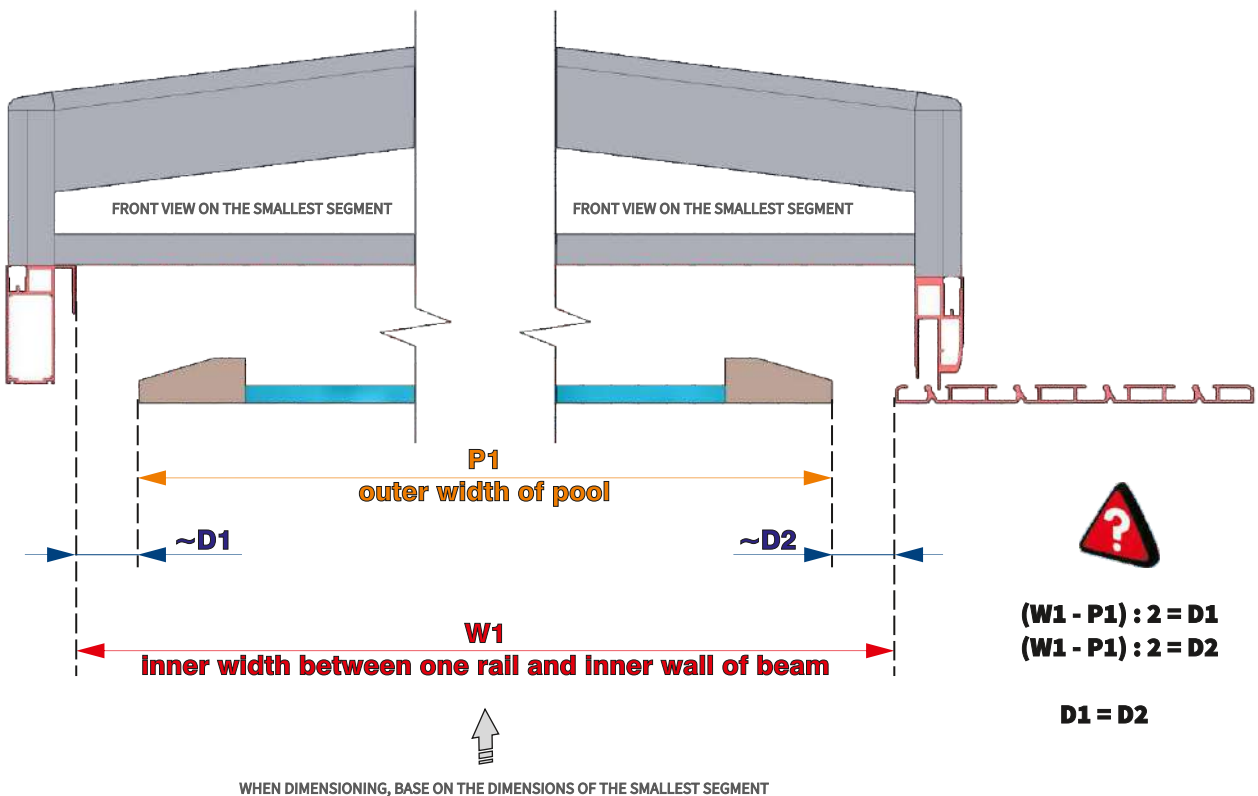

**(W1 - P1) : 2 = D1**  
**(W1 - P1) : 2 = D2**

**D1 = D2**

WHEN DIMENSIONING, BASE ON THE DIMENSIONS OF THE SMALLEST SEGMENT

## 2-TH STEP OF MEASUREMENT CENTRE PER LENGTH DIMENSIONS



  
 $(L1 - P2) : 2 = D3$   
 $(L1 - P2) : 2 = D4$   
**D3 = D5**

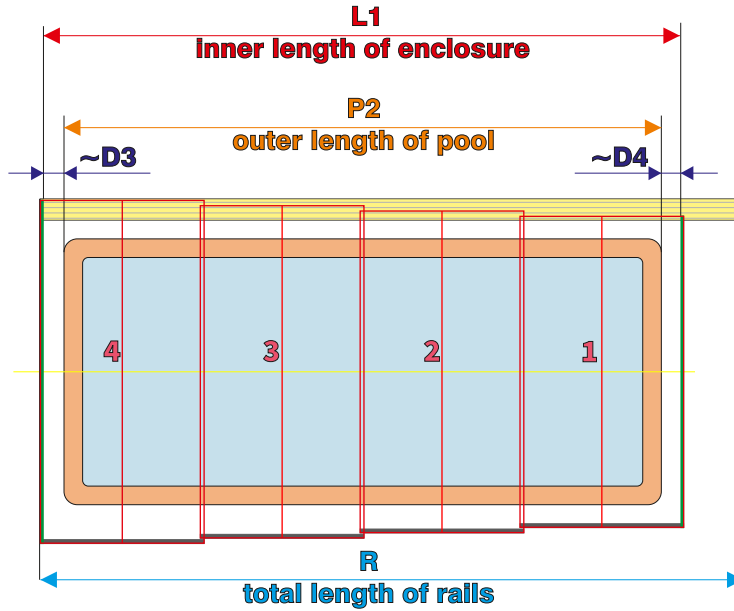

**EXTENSION RAIL FOR PARKZONE**  
 $R - L1$

## BASIC LAYOUT FOR CORRECT MEASUREMENT - ACCURATE CHECK OF LENGTH

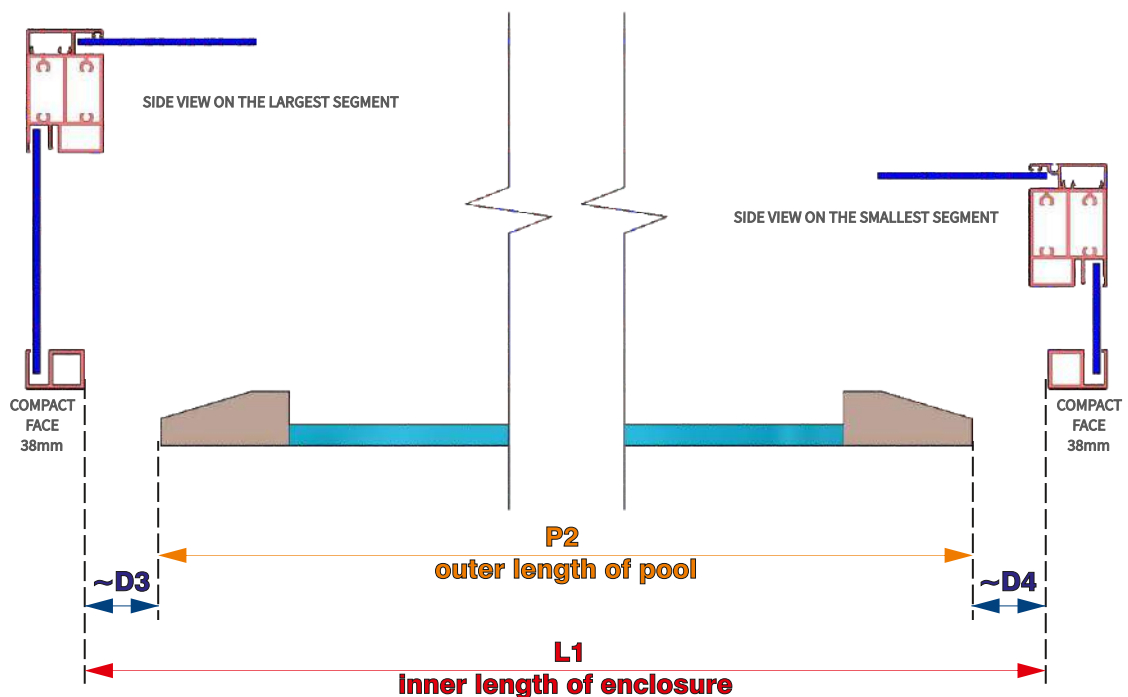

Alukov®

ITEM  
**FIXING**  
**THE LEADING LINES**

---

ASSEMBLING INSTRUCTIONS FOR ENCLOSURES

## FIXING THE ONE RAIL

**STEP - 1** CONNECTING OF THE SEVERAL PARTS OF RAIL ALONG TOTAL LENGHT

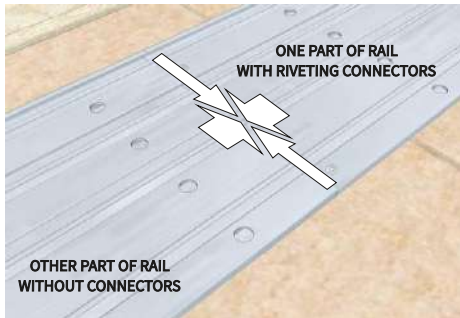

**STEP - 2** EVENTUALLY POSITION OF THE RAIL - MARKED ON SURFACE FOR CHECK DURING DRILL

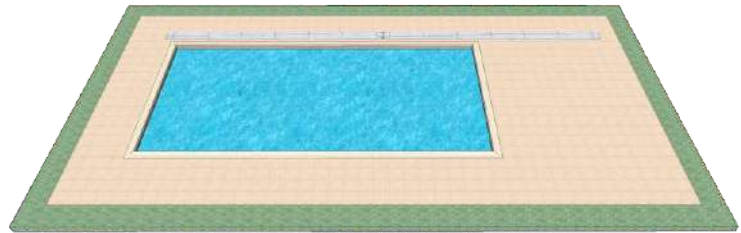

**THIS ONE RAIL IS PARALLEL ALONG THE POOL, THEREFORE KEEP SUFFICIENT DISTANCE ACCORDING RECCOMENDED MEASUREMENT**

**STEP - 3**



Make visual check, if this **one complet rail** is in perfect line.

**STEP - 4**

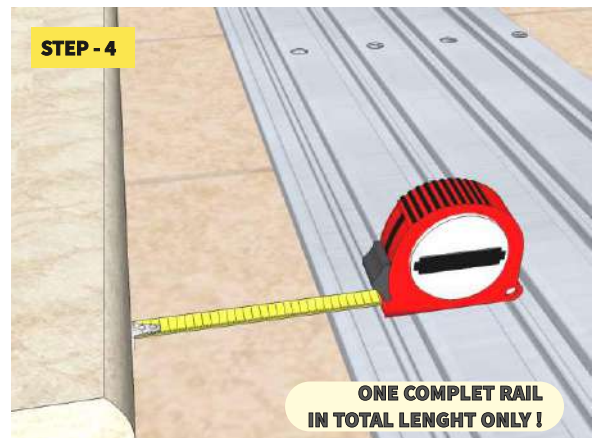

Check a distance between one complet rail and outer edge of pool in more positions of measurement

### PLASTIC CAPS



Standard rail is predrilling in produce, usually rail fixed to concrete or pavement surface by plastic raw-plugs Ø8mm - use drill Ø8mm .

Amount of raw-plugs depends on lenght of rail and especially on specification of ground surface.

For wooden floor use spiral dives.



Need to underlay the rail with aluminium strips

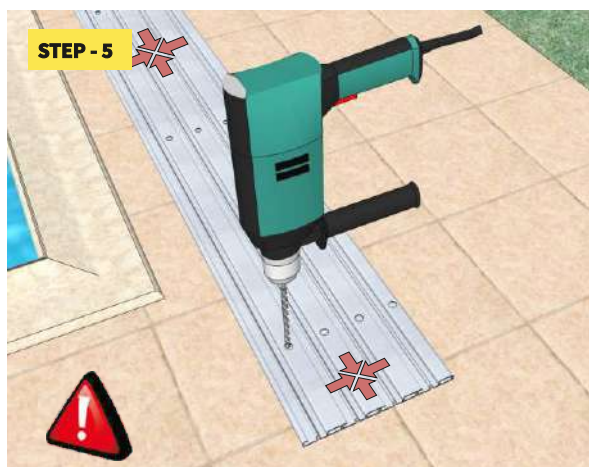

**STEP - 5**

Drilling through this one complet rail according the number of predrilling holes in rail.  
**During drilling avoid the shifting of rail!**



**STEP - 6**

Important to clean the rails of dirt, the best way is to use vacuum cleaner and sweep carefully.

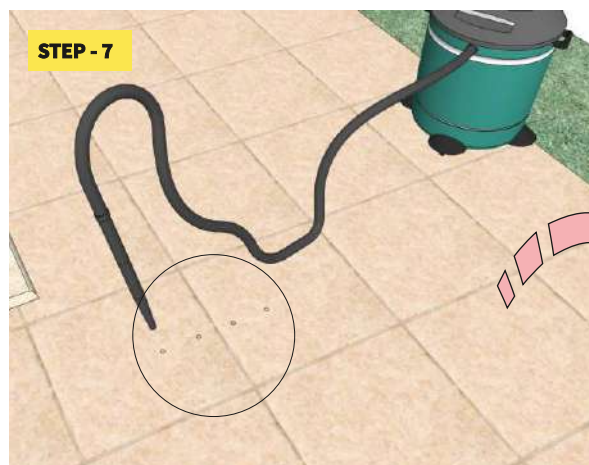

**STEP - 7**

Don't forget to clean the dirt from drilling holes under the rails, use vacuum cleaner.

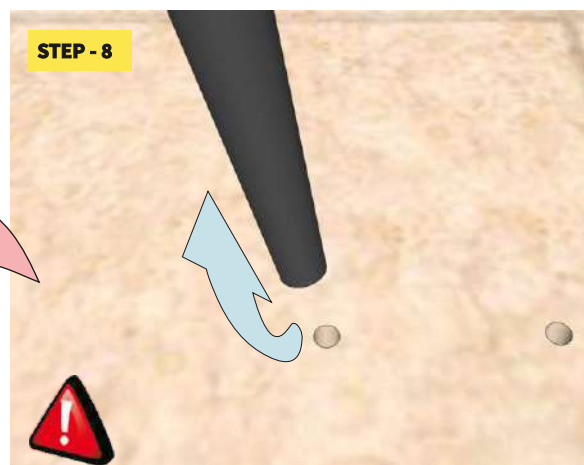

**STEP - 8**

Not cleaned dirt may cause decrease strength of this joint!

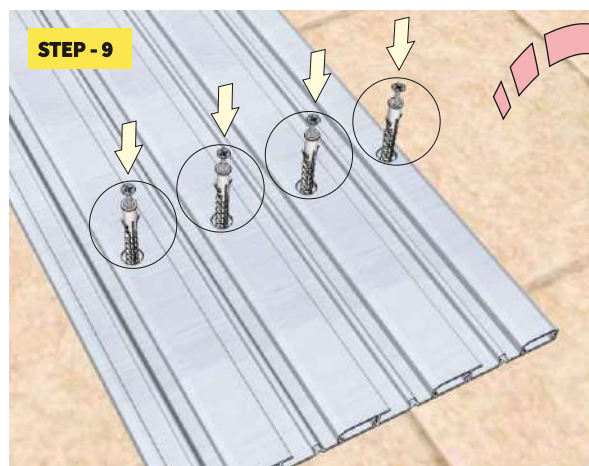

**STEP - 9**

Insert the raw-plug into a cleaned hole

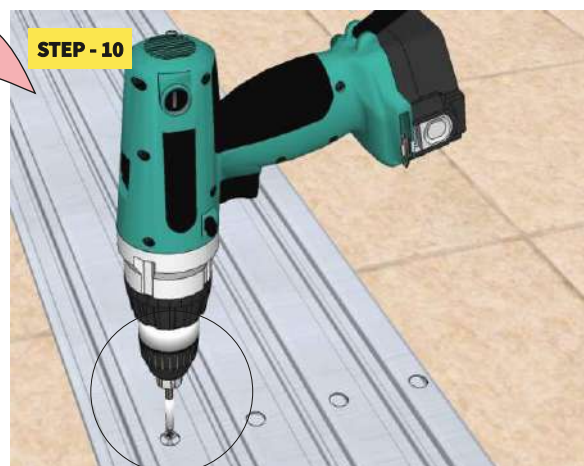

**STEP - 10**

Slightly hammer in tight the rail to the ground by screws!

## CLEANING THE RAILS

### STEP - 1

AFTER FIX THE RAIL TO THE GROUND PROCEED TO ...

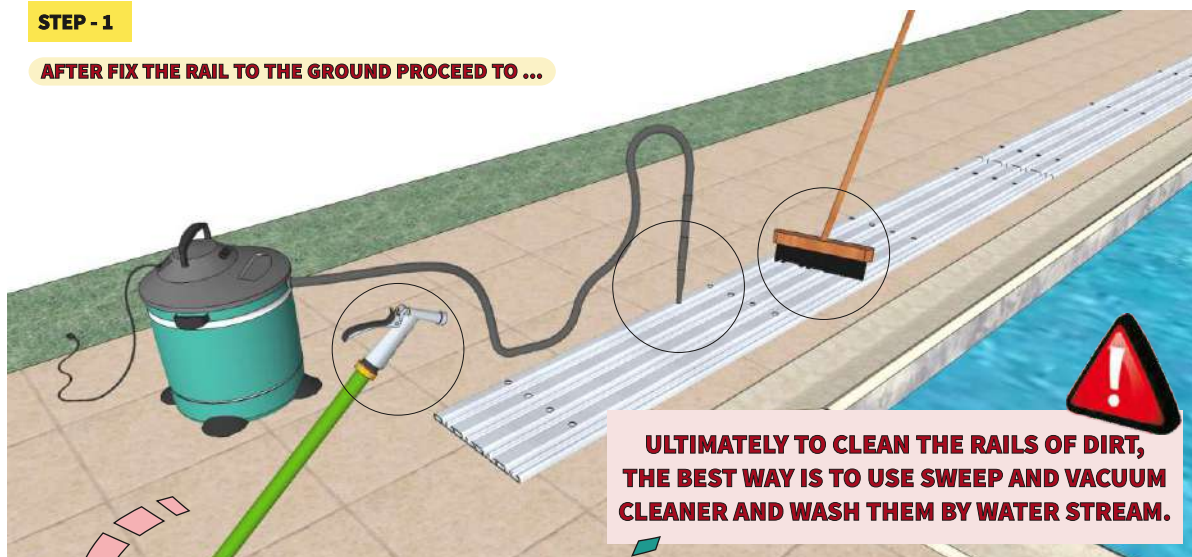

NOT CLEANED RAILS AND DIRT MAY CAUSE DAMAGE OF ANODIZE COATING!



### STEP - 2 AFTER CLEAN MAYBE CONTINUE !

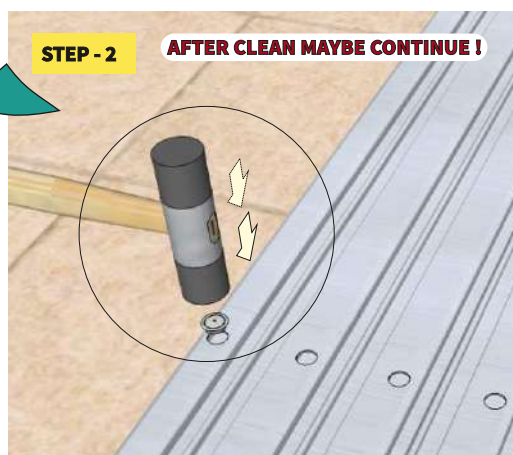

Put plastic caps on the all holes and slightly beat them in by rubber hammer (colour of the caps depends on rails colour)

### STEP - 3

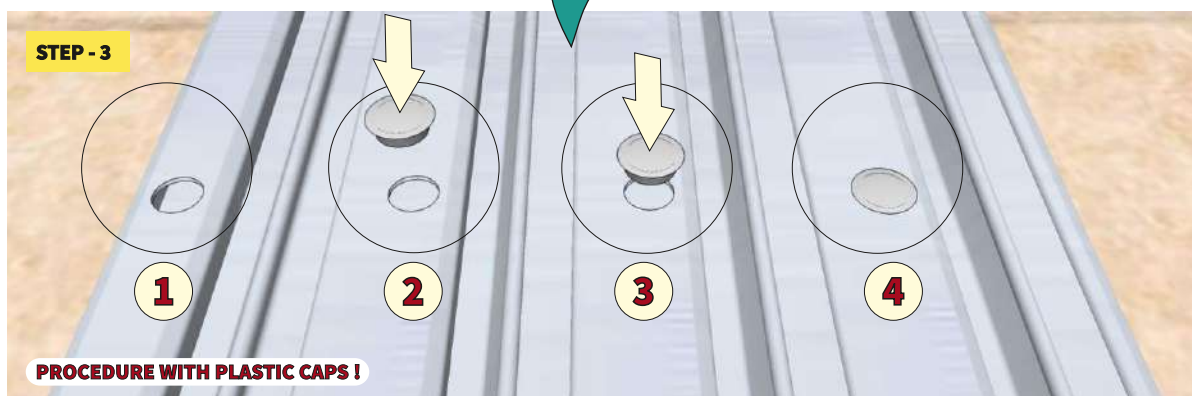



ITEM

**PREPARE THE SEGMENTS  
BEFORE PUTTING ON RAIL**

---

ASSEMBLING INSTRUCTIONS FOR ENCLOSURES

## **ARRESTMENT OF SEGMENT WITH LOCK**

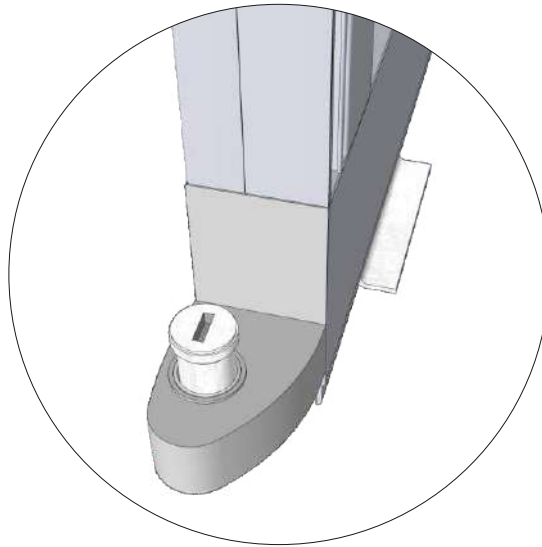

### **THE DEPENDENT SEGMENTS**

***LOCK ARRESTMENT - FOR LARGEST SEGMENT ONLY***



### **THE INDEPENDENT SEGMENTS**

***LOCK ARRESTMENT - FOR EACH SEGMENT***

ITEM

# **FIX A LOCK OF ARRESTMENT**

## THE ARRESTMENT OF SEGMENT

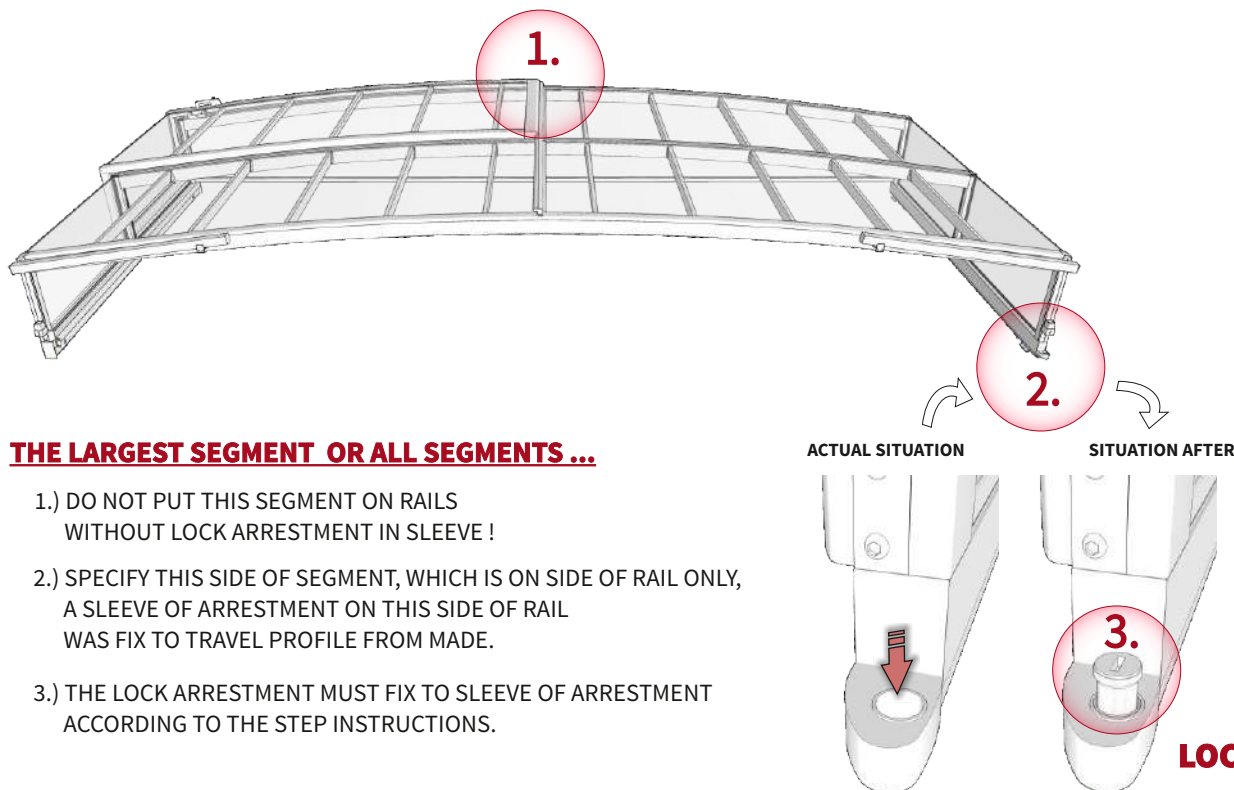

### THE LARGEST SEGMENT OR ALL SEGMENTS ...

- 1.) DO NOT PUT THIS SEGMENT ON RAILS WITHOUT LOCK ARRESTMENT IN SLEEVE !
- 2.) SPECIFY THIS SIDE OF SEGMENT, WHICH IS ON SIDE OF RAIL ONLY, A SLEEVE OF ARRESTMENT ON THIS SIDE OF RAIL WAS FIX TO TRAVEL PROFILE FROM MADE.
- 3.) THE LOCK ARRESTMENT MUST FIX TO SLEEVE OF ARRESTMENT ACCORDING TO THE STEP INSTRUCTIONS.

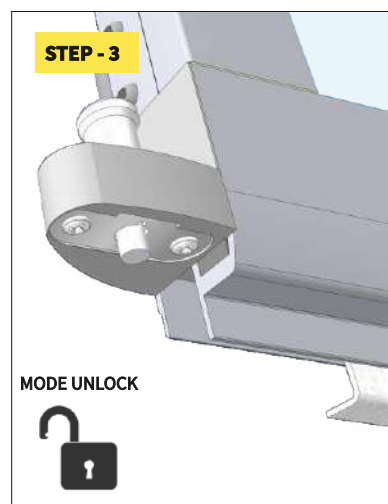
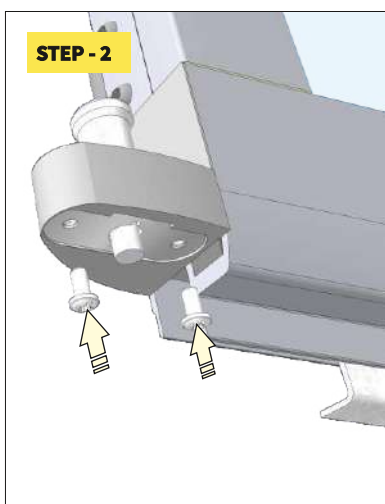
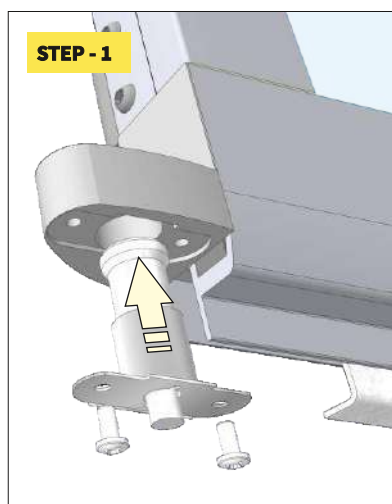

EXTRA STRONG TIGHTENING  
COULD DAMAGE THE THREAD IN THE SLEEVE !



USE HAND CROSS - SCREWDRIVER FOR FIX OF THE LOCKS !

## **BRACKET**

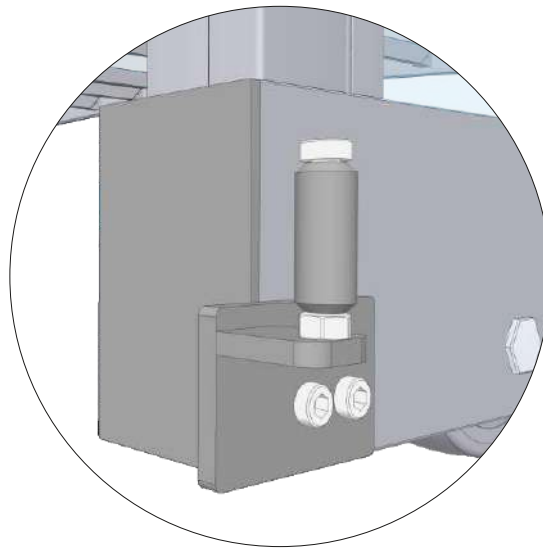

### **THE DEPENDENT SEGMENTS**

***BRACKET FOR EACH DESCENT SEGMENT***



### **THE INDEPENDENT SEGMENTS**

***WITHOUT BRACKETS***

ITEM

# **FIX A BRACKET**

## FIX A BRACKET ON EACH DESCENT SEGMENT

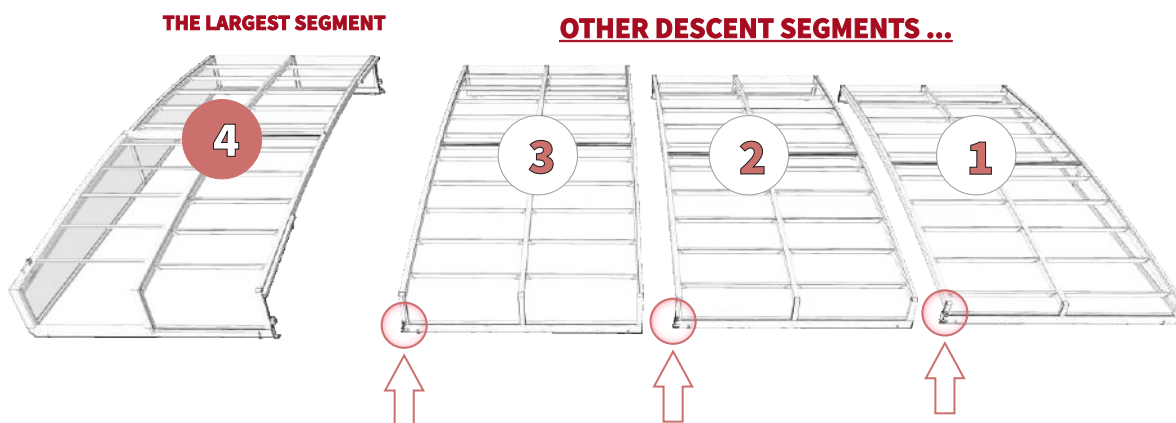

### THE BRACKETS

each bracket fix to end of travel profile ( outer side of segment ) - in each overlapping of segments according to predrilling holes from made !

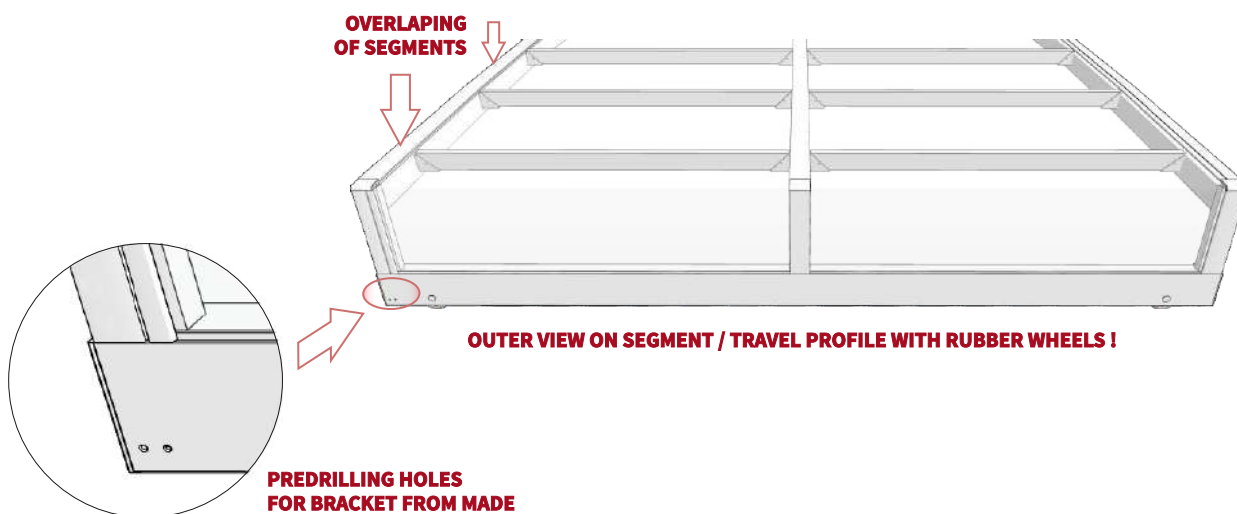

### STEP - 1

#### COMPONENT EACH BRACKET

#### FIX MATERIAL

**PLASTIC CAP - NUT ( 2 pce )**

**BOLT M6x45 mm ( 2 pce )**

**NUT M6 ( 2 pce )**

**PLASTIC CAP - NUT ( 2 pce )**

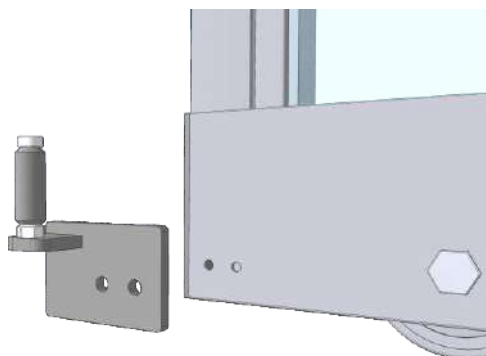
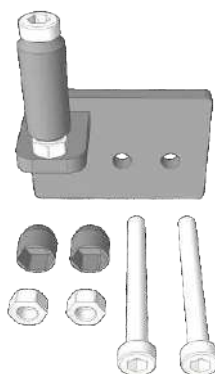

**OUTER VIEW ON SEGMENT / TRAVEL PROFILE WITH RUBBER WHEELS !**

**STEP - 2**

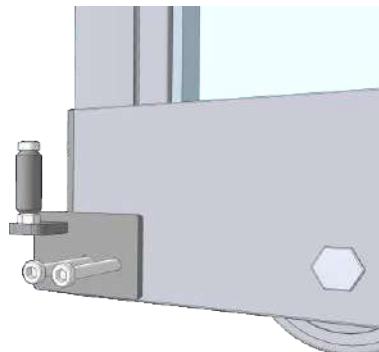

**OUTER SIDE OF TRAVEL PROFILE**

**STEP - 3**

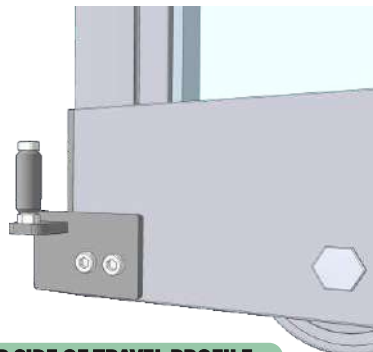

**OUTER SIDE OF TRAVEL PROFILE**

*Screws for fix of the bracket  
put to predrilling holes from made.*

**STEP - 4**

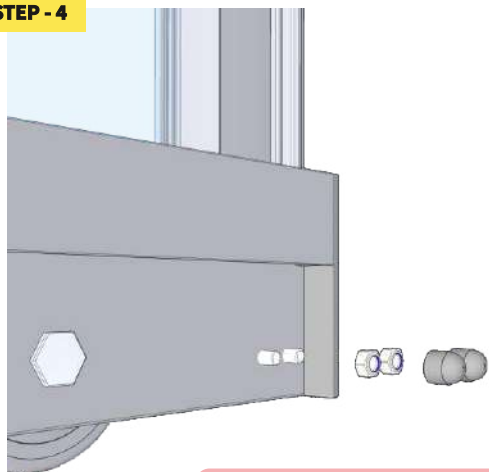

**INNER SIDE OF TRAVEL PROFILE**

**STEP - 5**

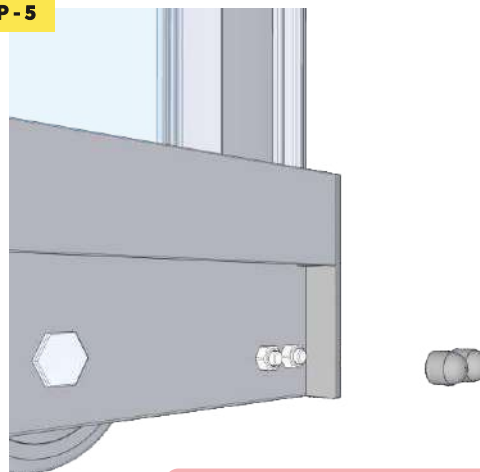

**INNER SIDE OF TRAVEL PROFILE**

**STEP - 6**

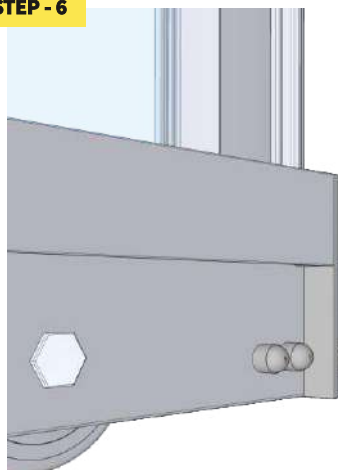

**INNER SIDE OF TRAVEL PROFILE**

## ROLL

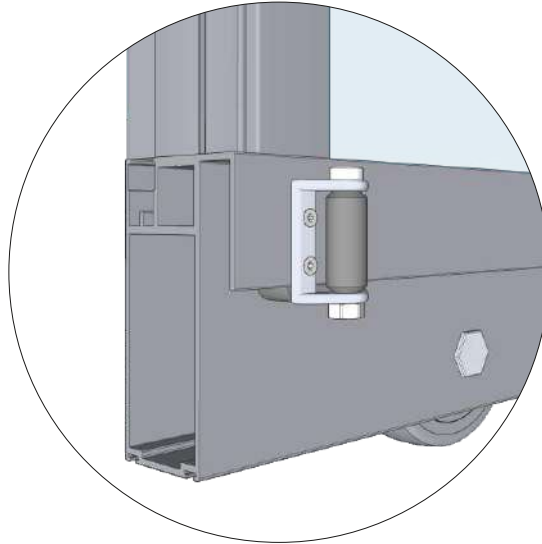

### **THE DEPENDENT SEGMENTS**

**NO ROLL FOR SMALLEST SEGMENT  
ONE ROLL MUST FIX TO EACH ASCENDING SEGMENT**



### **THE INDEPENDENT SEGMENTS**

**NO ROLLS FOR SMALLEST SEGMENT  
TWO ROLLS ARE FIXING IN EACH ASCENDING SEGMENT**

# ITEM **FIX A ROLL**

## THE DEPENDENT SEGMENTS

### NOTES:

ONE ROLL MUST FIX ON INNER SIDE OF TRAVEL PROFILE (SIDE OF ENCLOSURE - RUBBER WHEELS)

### STEP - 1

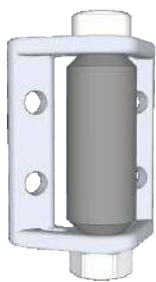

**COMPONENT  
EACH ROLL**

### FIX MATERIAL

4 pce bolt M4 are tighteen  
to inner side of travel profile

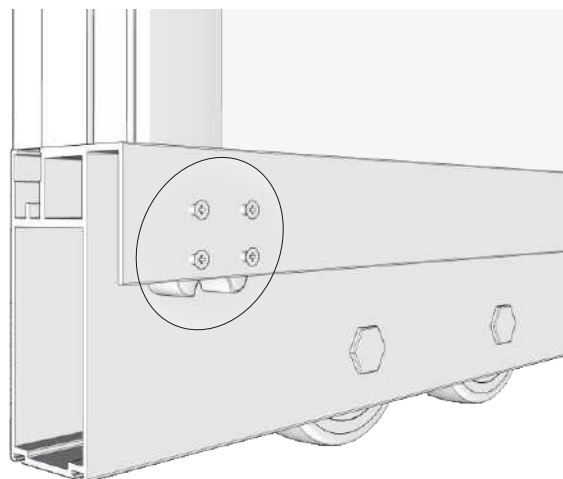

**INSIDE SEGMENT / TRAVEL PROFILE WITH RUBBER WHEELS !**

**KEEP THE FOLLOWING INSTRUCTIONS FOR COMPLETION OF ROLL !**



### STEP - 2

## THE DEPENDENT SEGMENTS

### NOTES:

TWO ROLL ARE FIXING ON SAME INNER SIDE OF TRAVEL PROFILE (SIDE OF ENCLOSURE - RUBBER WHEELS)

### NO STEP - OK



**INSIDE SEGMENT / TRAVEL PROFILE WITH RUBBER WHEELS !**

## FIX A ROLL ON OVERLAPPING OF SEGMENTS

**STEP - 2**

**THE LARGEST SEGMENT**

**OTHER DESCENT SEGMENTS ...**

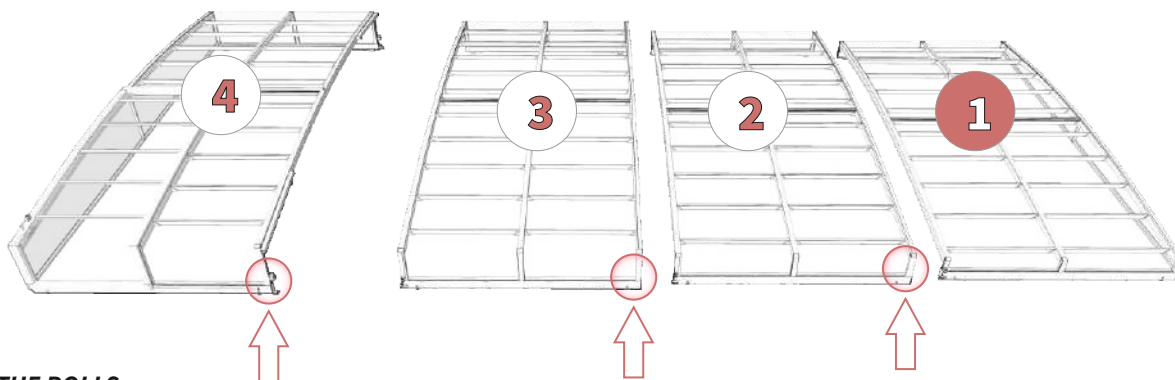

### THE ROLLS

each roll fix to end of travel profile ( inner side of segment ) - in each overlapping of segments according to predrilling holes from made !



**STEP - 2.1**

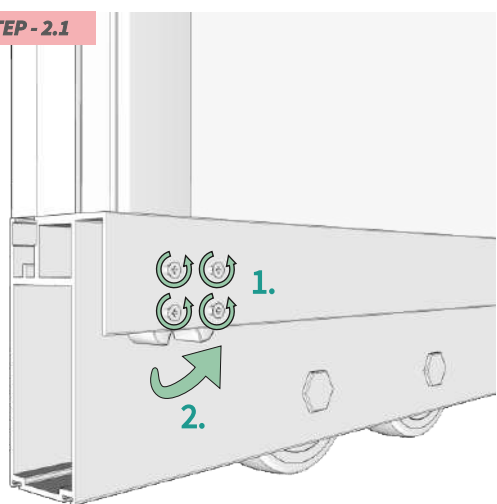

INNER SIDE OF SEGMENT

**STEP - 2.2**

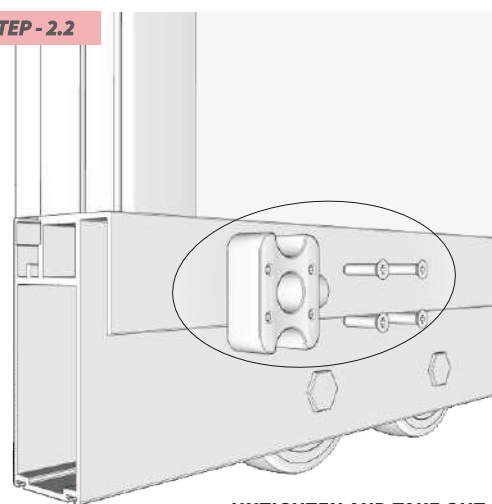

UNTIGHTEN AND TAKE OUT

**STEP - 2.3**

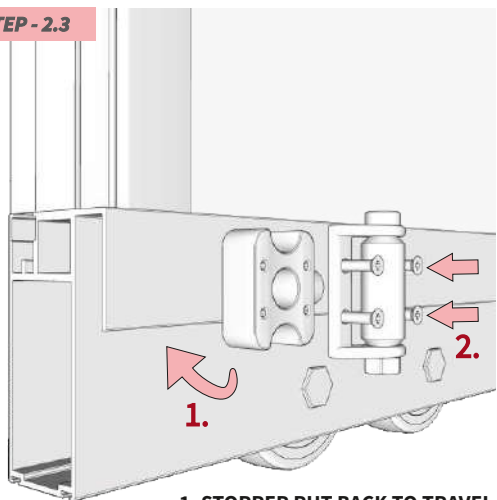

1. STOPPER PUT BACK TO TRAVEL  
2. A ROLL ATTACH WITH BOLTS ...

**STEP - 2.4**

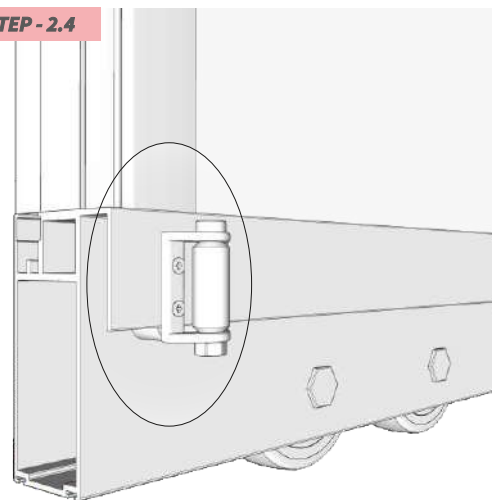

... A COMPLET TIGHTEN PER PICTURE

## **OUTER STOPPER**

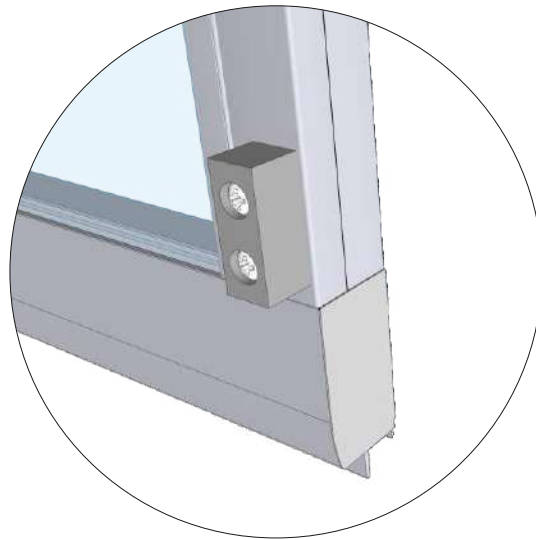

### **THE DEPENDENT SEGMENTS**

***OUTER STOPPER FOR EACH DESCENT SEGMENT***



### **THE INDEPENDENT SEGMENTS**

***WITHOUT OUTER STOPPERS***

ITEM

# **FIX AN OUTER STOPPER**

**FIX AN OUTER STOPPER ON EACH DESCENT SEGMENT**

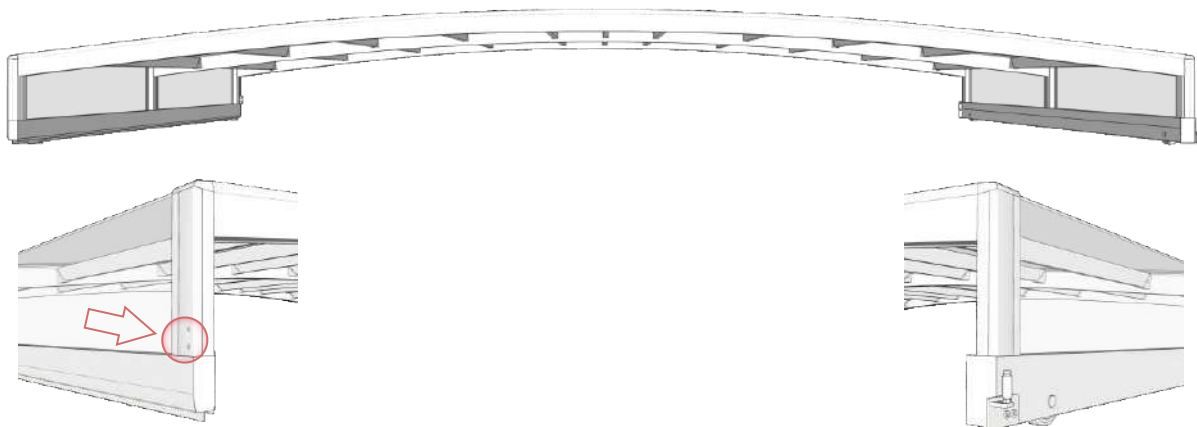

**OTHER DESCENT SEGMENTS ...**

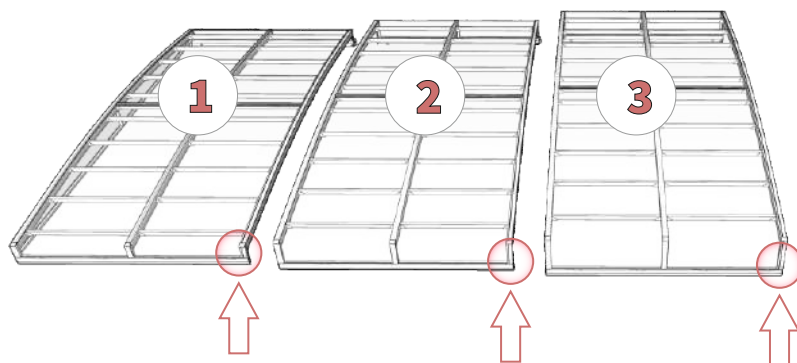

**THE LARGEST SEGMENT**

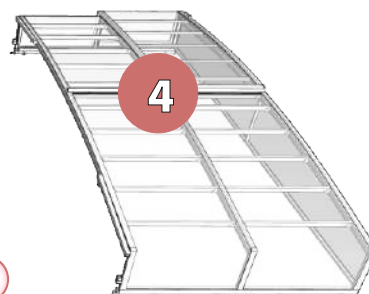

**THE OUTER STOPPERS**

*each stopper fix above an upper edge of travel profile - in each overlapping of segments according to predrilling holes from made !*

**SIDE - WHEELS FOR RAIL**

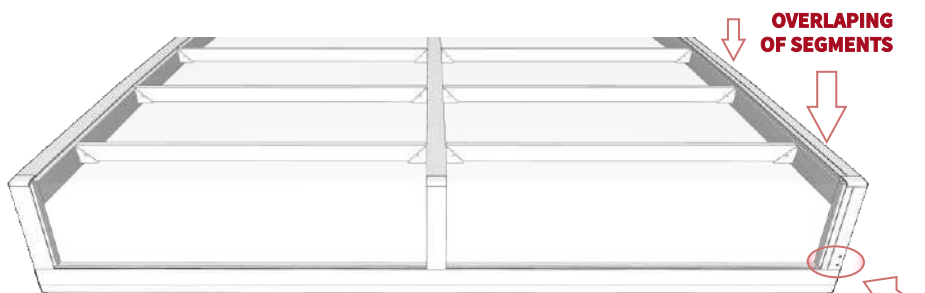

**OUTER VIEW ON SEGMENT / TRAVEL PROFILE WITH WHEELS FOR RAIL !**

**PREDRILLING HOLES FOR OUTER STOPPER FROM MADE**

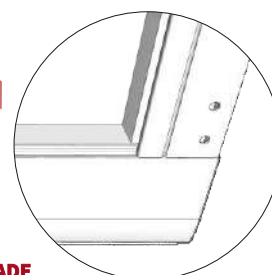

**STEP - 1**

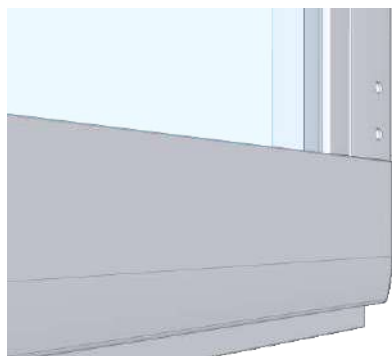

**COMPONENT**  
**EACH OUTER STOPPER**

**FIX MATERIAL**  
**SCREW 6,3x50 mm (2 pce )**

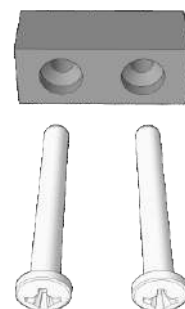

**OUTER VIEW ON SEGMENT / TRAVEL PROFILE WITH WHEELS FOR RAIL !**

**STEP - 2**

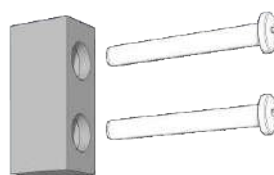
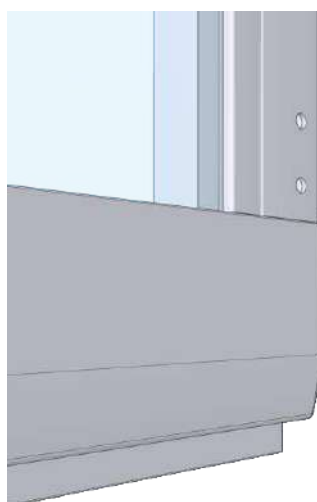

*Screws for fix of the bracket  
put to predrilling holes from made.*

**OUTER SIDE OF TRAVEL PROFILE**

**STEP - 3**

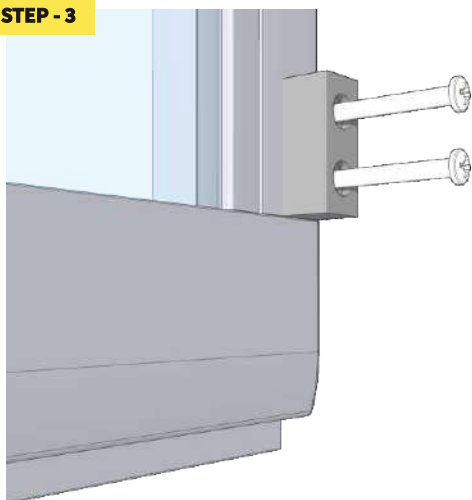

**STEP - 4**

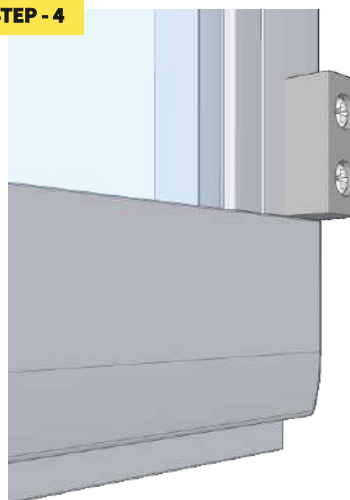

Alukov®

ITEM  
**THE SEGMENTS  
PUTTING ON RAIL**

---

ASSEMBLING INSTRUCTIONS FOR ENCLOSURES

## PUTTING OF ALL SEGMENTS ON THE RAILS

SEGMENT NR.1 / STEP - 1

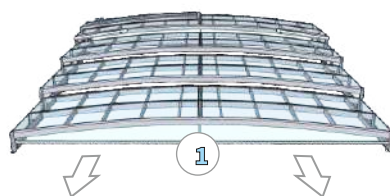

SEGMENT NR.1 / STEP - 2

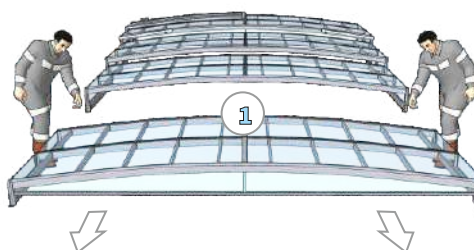

SEGMENT NR.1 / STEP - 3

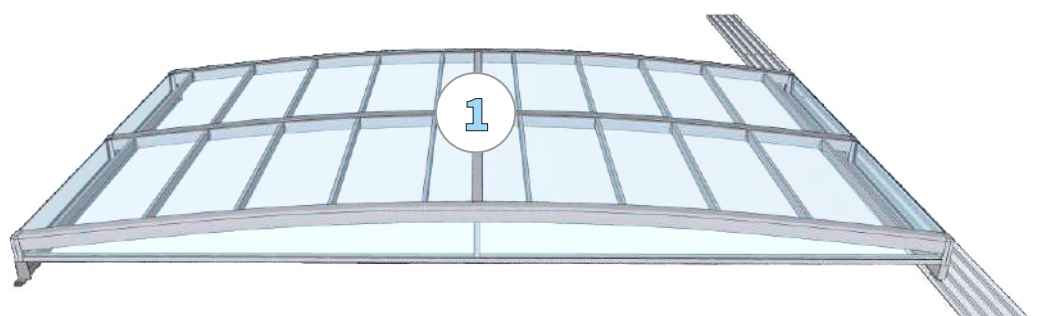

## DETAIL - LIFT UP / HANG UP OF EACH SEGMENT BESIDE THE SMALLEST SEGMENT

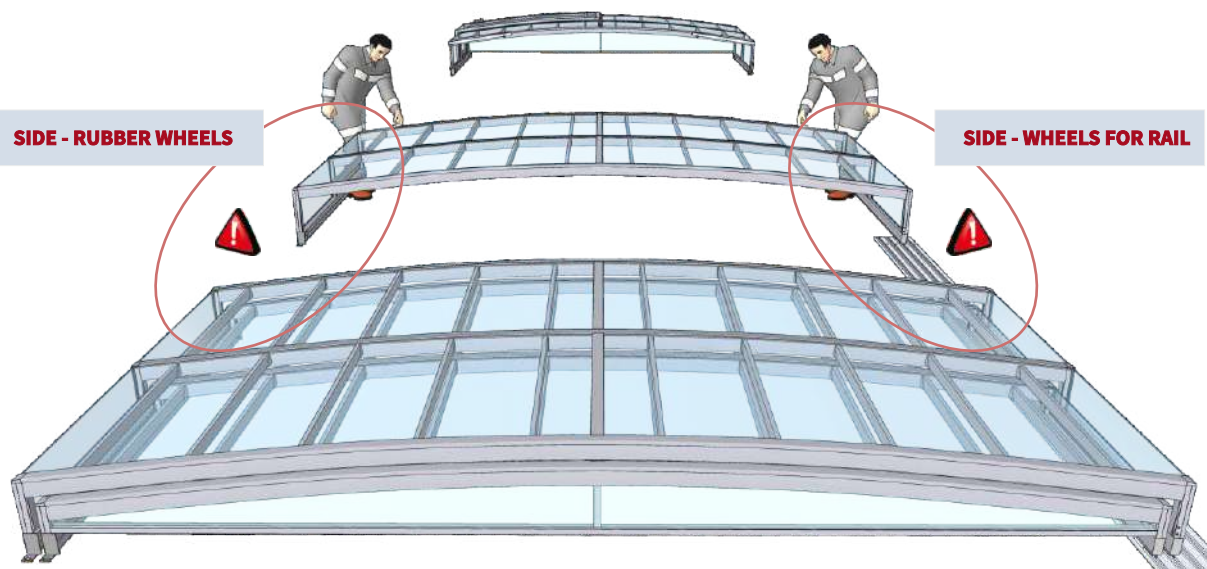

### SIDE - RUBBER WHEELS

\* Move a higher segment to overlapping between the segments -before the bracket on lower segment (1).

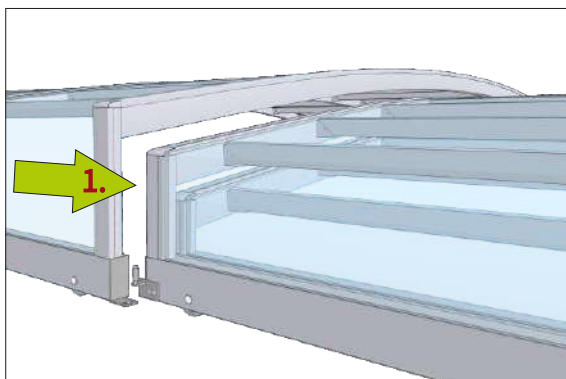
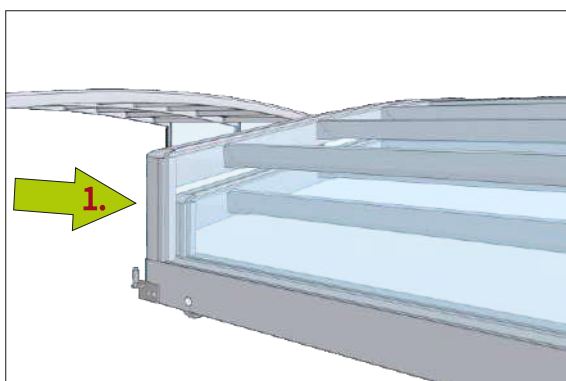

### SIDE - WHEELS FOR RAIL

\* ATTENTION - while putting a higher segment on the rail (1), take a care about sufficient distance between arrestment sheets and the ground.

**Risk of sheets or pavement damage !**

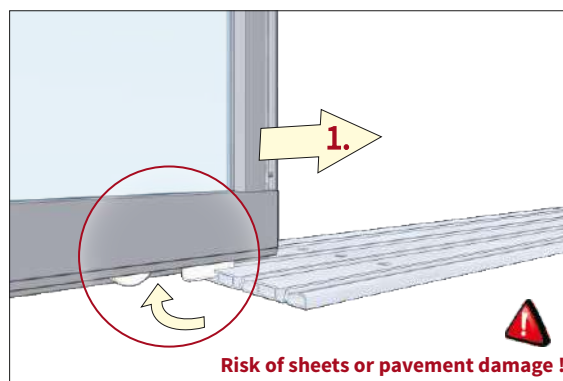

**Risk of sheets or pavement damage !**

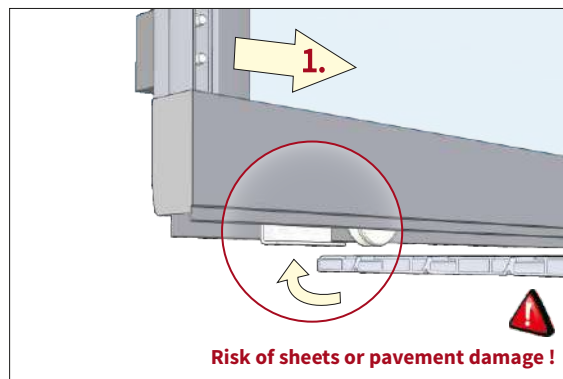

**Risk of sheets or pavement damage !**

### SIDE - RUBBER WHEELS

\* Edge of the higher segment lift up (2) and hang up (3) to the bracket on lower segment - then move the segment further (4) and this segment pull down / put on ground (5).

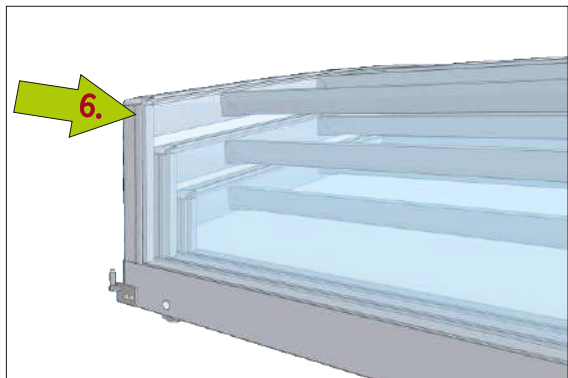
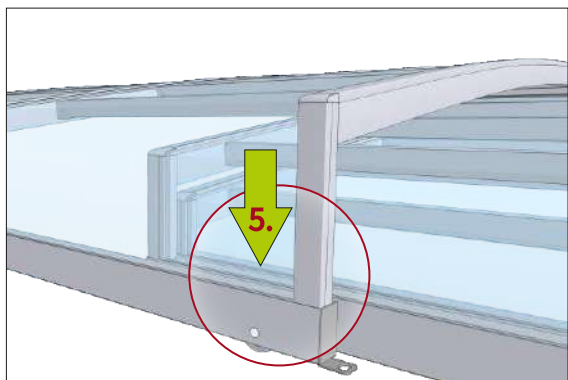
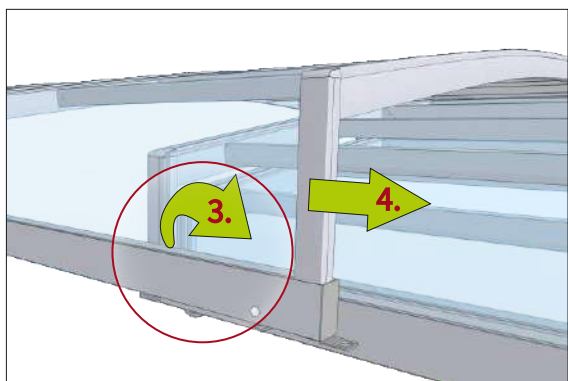
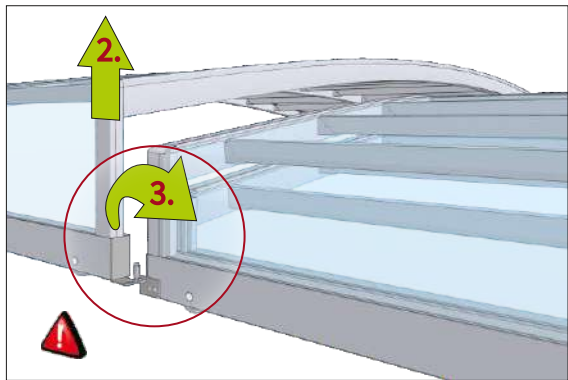

### SIDE - WHEELS FOR RAIL

\* Higher segment on this side of rail do not lift the segment anymore (2), only move it (3) according to the situation on the opposite side of the pool (4)!

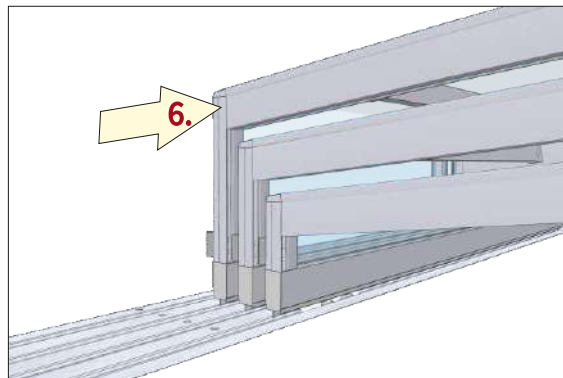
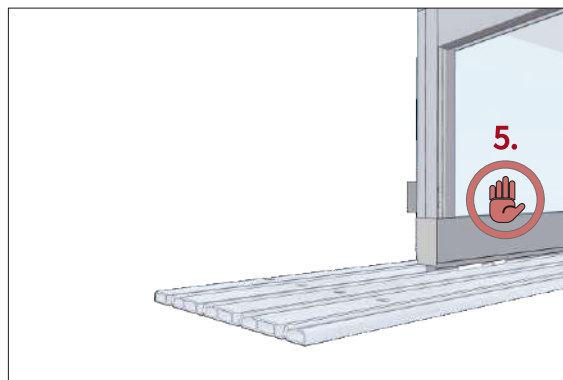
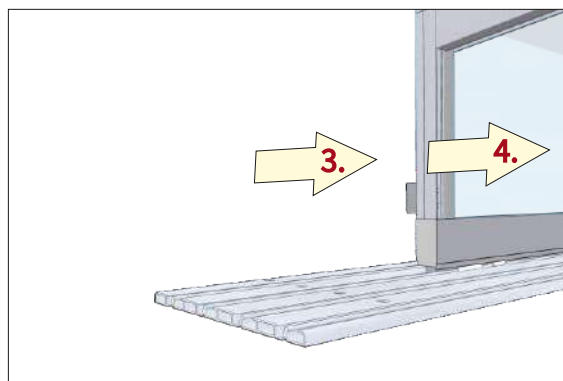
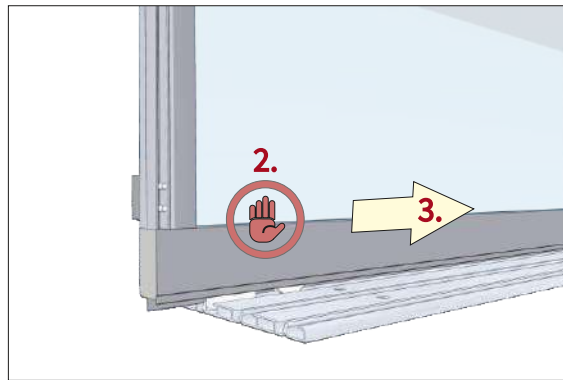

**SEGMENT NR.2 / STEP - 1**

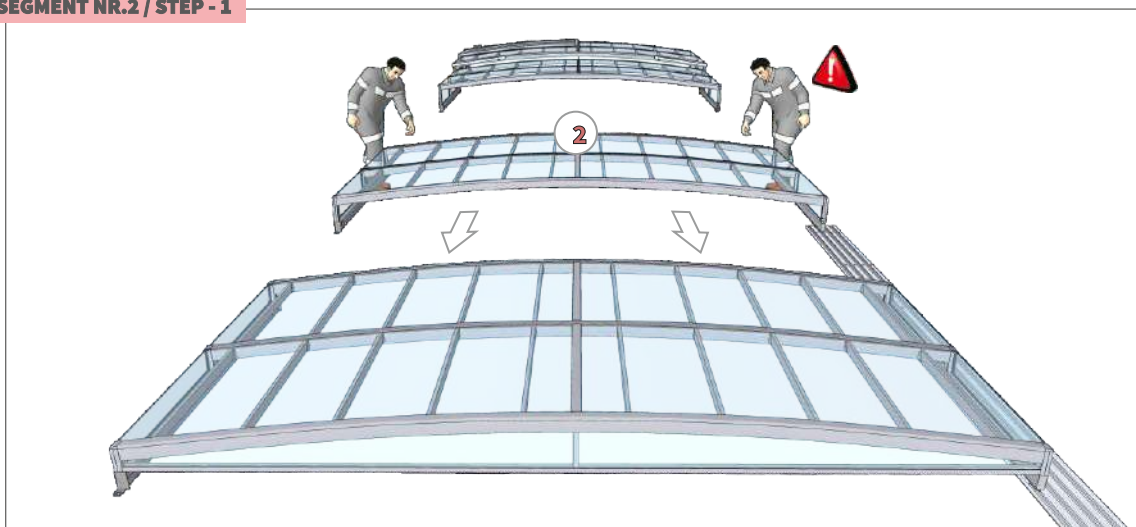

**SEGMENT NR.2 / STEP - 2**

\* Take higher segment over bracket and then segment put down, so bracket is hide in groove of the travel profile.

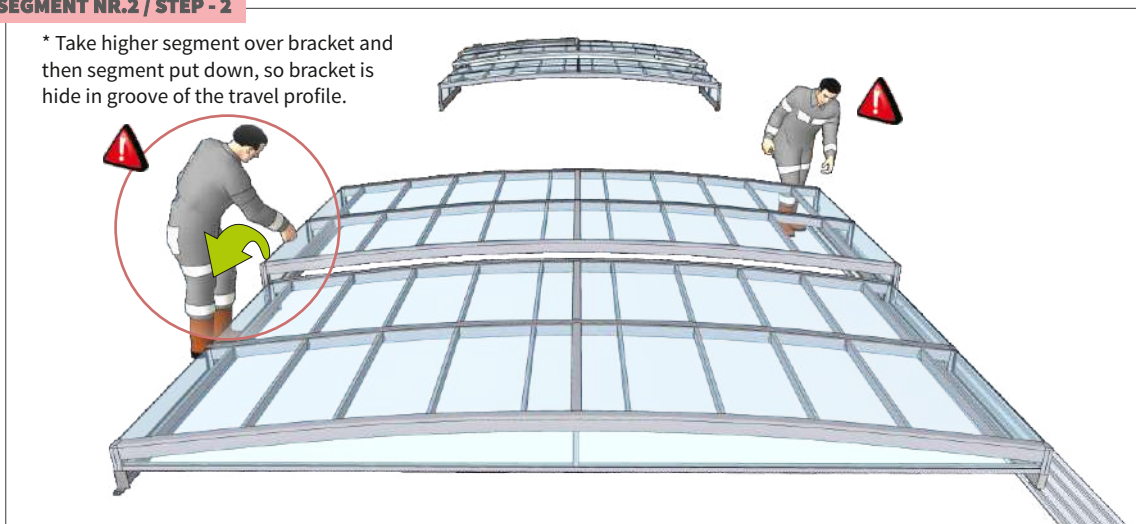

**SEGMENT NR.2 / STEP - 3**

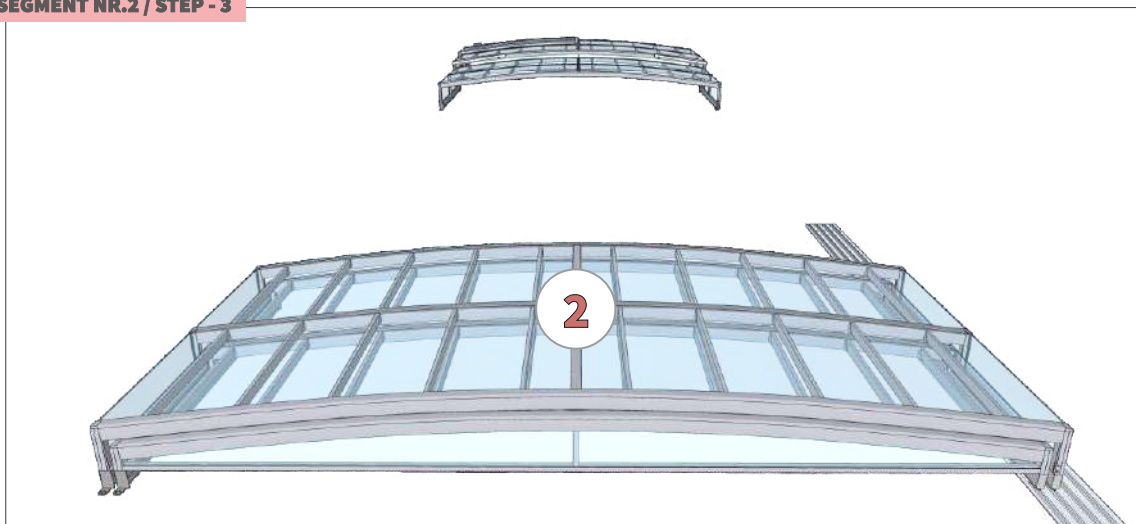

**SEGMENT NR.3 / STEP - 1**

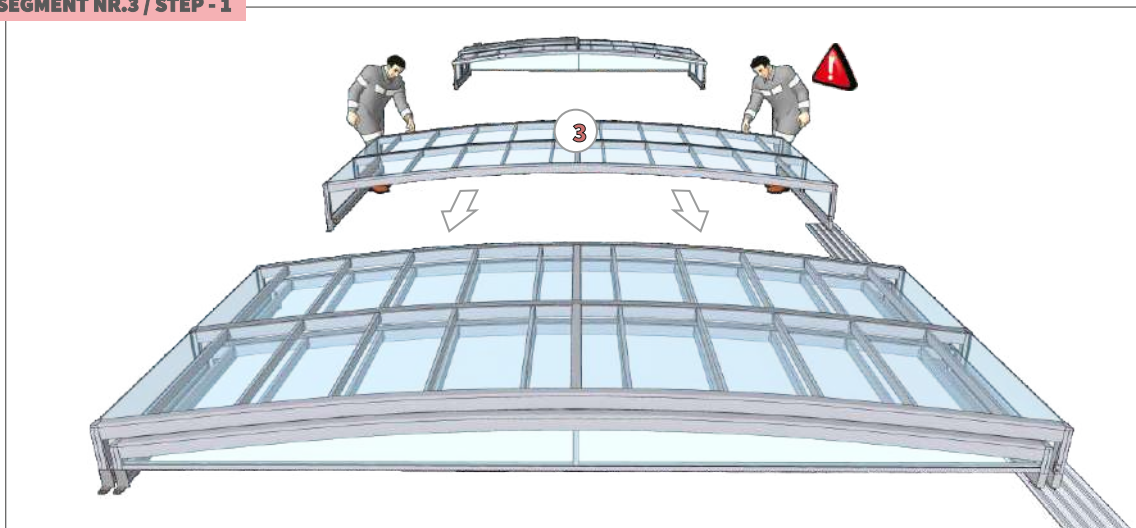

**SEGMENT NR.3 / STEP - 2**

\* Take higher segment over bracket and then segment put down, so bracket is hide in groove of the travel profile.

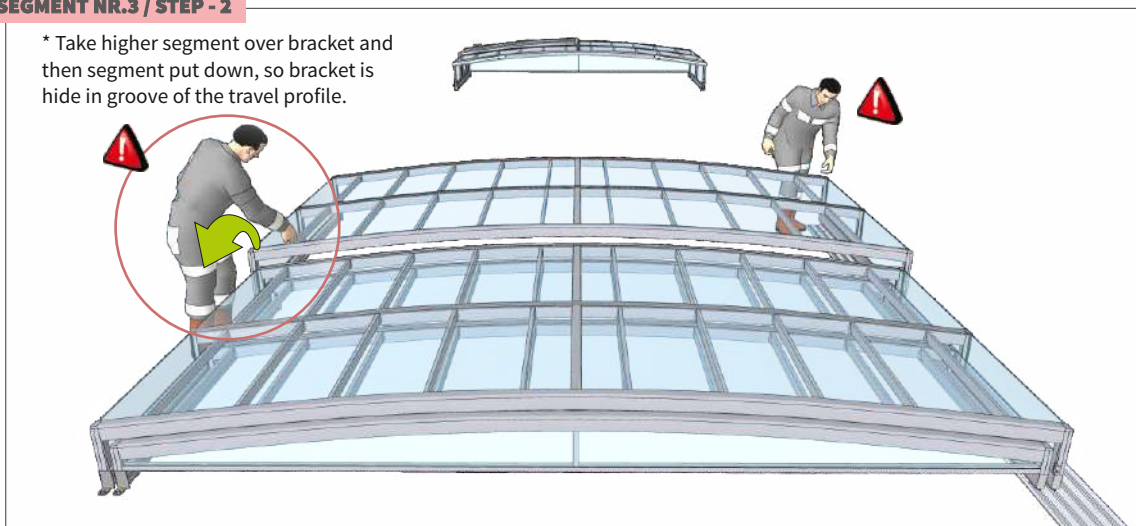

**SEGMENT NR.3 / STEP - 3**

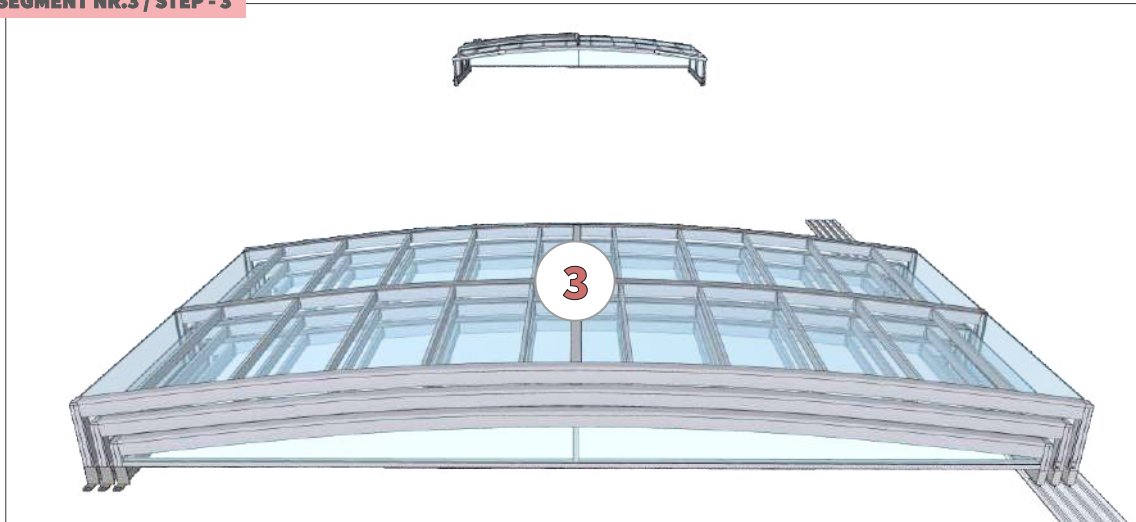

**SEGMENT NR.4 / STEP - 1**

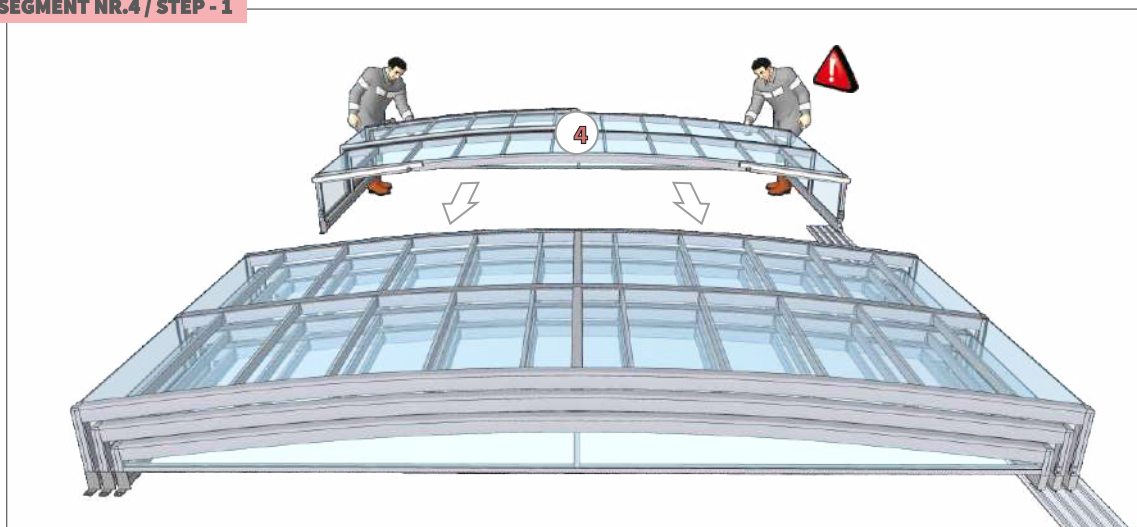

**SEGMENT NR.4 / STEP - 2**

\* Take higher segment over bracket and then segment put down, so bracket is hide in groove of the travel profile.

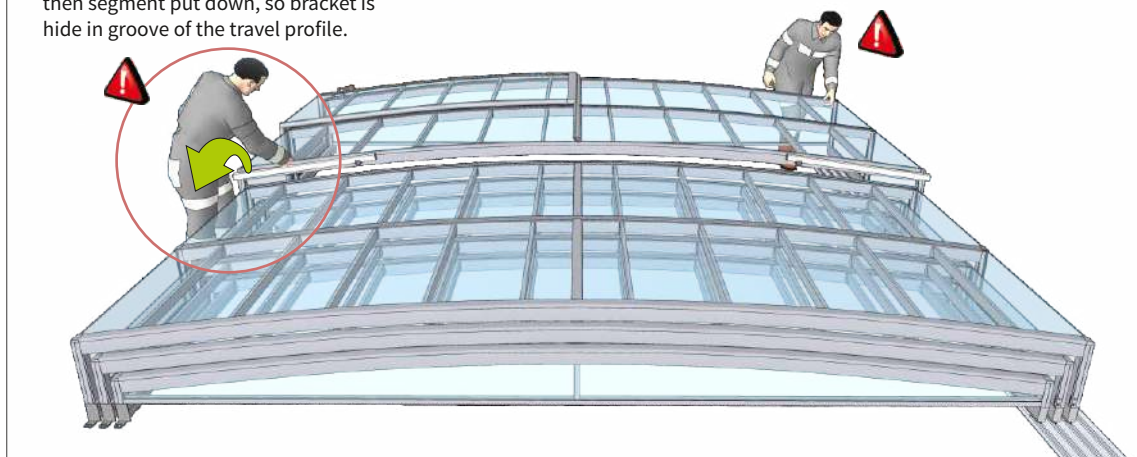

**SEGMENT NR.4 / STEP - 3**

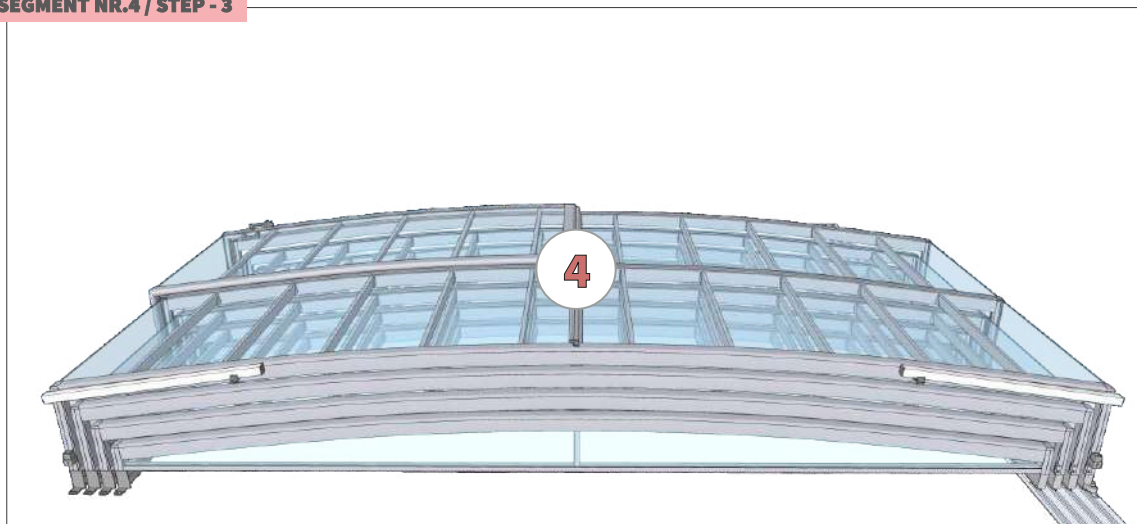

## **INNER STOPPER**

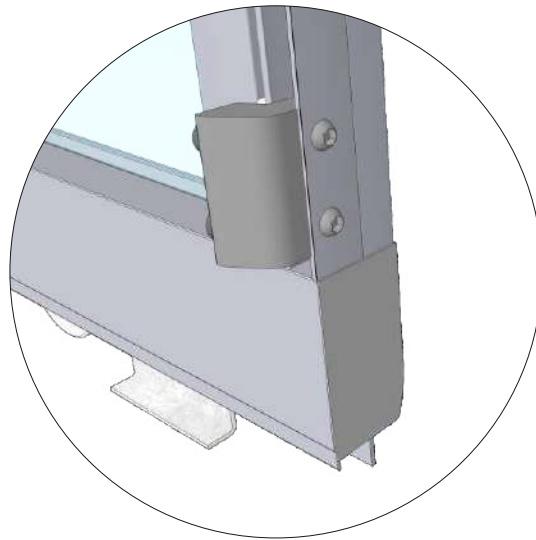

### **THE DEPENDENT SEGMENTS**

***INNER STOPPER FOR EACH DESCENT SEGMENT***



### **THE INDEPENDENT SEGMENTS**

***WITHOUT INNER STOPPERS***

ITEM

# **FIX AN INNER STOPPER**

## FIX AN INNER STOPPER ON EACH ASCENDING SEGMENT

**OTHER ASCENDING SEGMENTS ...**

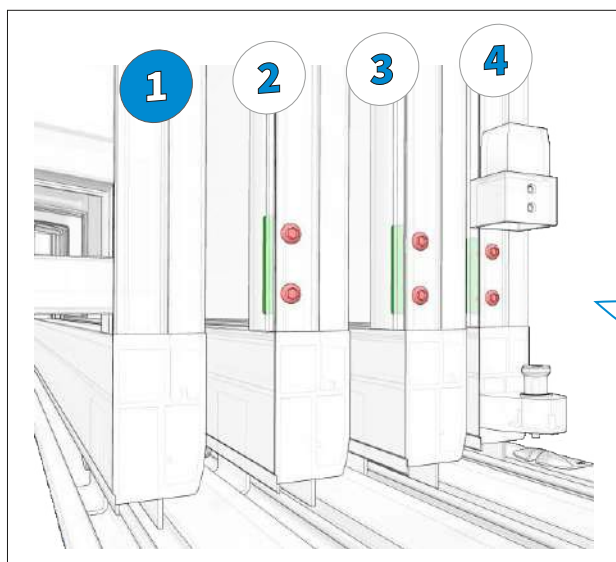
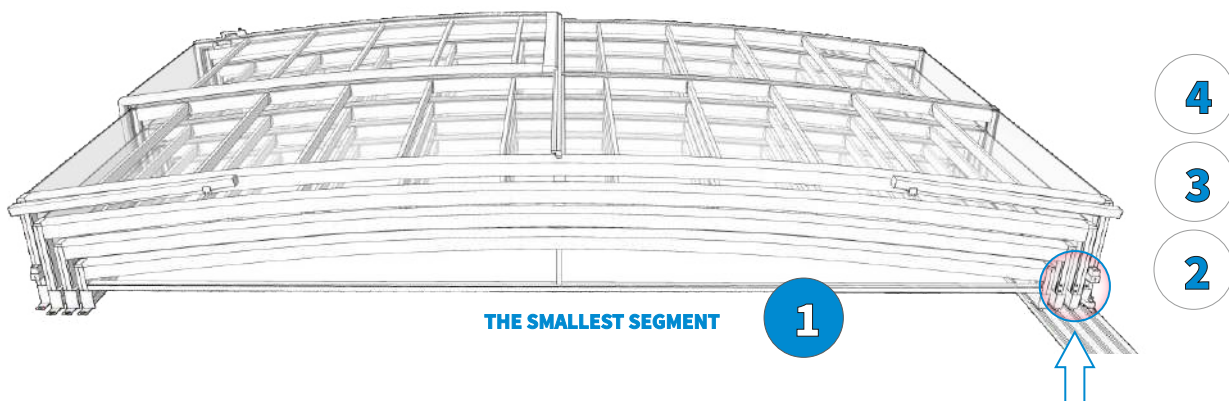

### STEP - 1

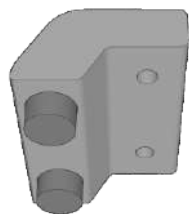

**COMPONENT FROM PACKAGE EACH INNER STOPPER**



**FIX MATERIAL ON REVELANT SEGMENT NOW**



**TIGHTENED BOLT**  
(2 pce - shown in red mark)  
**WASHER WITH THREADS HOLE**  
(1 pce - green mark)

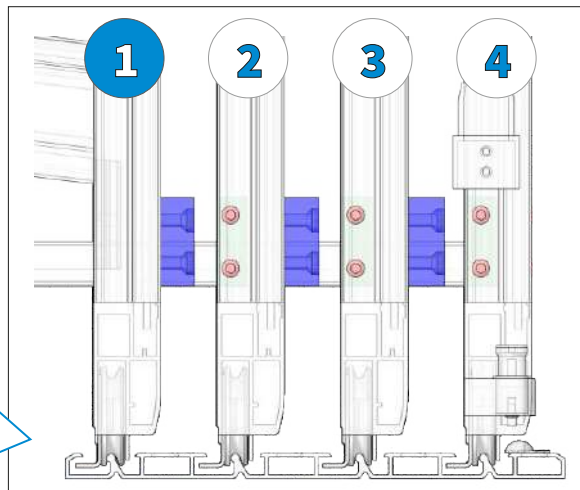

*Example of fixing outer stoppers against following inner stoppers*

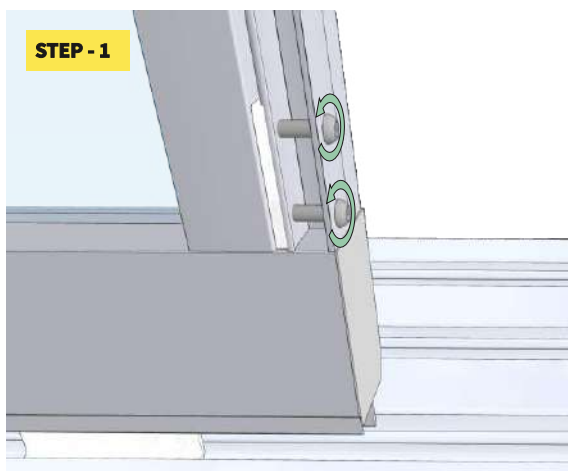

**STEP - 1**

**INNER SIDE OF TRAVEL PROFILE**

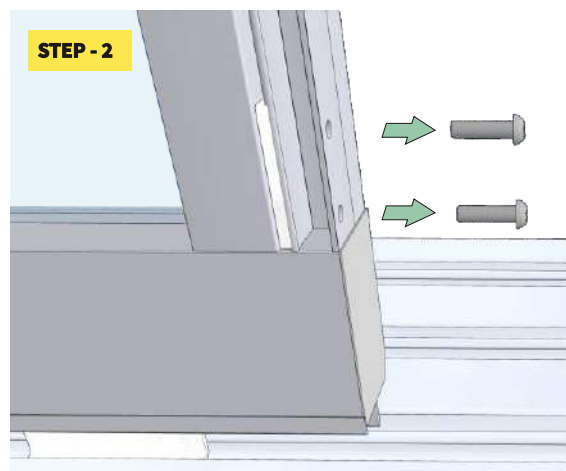

**STEP - 2**

*Both bolts unscrewed from segment, this washer stay in groove still.*

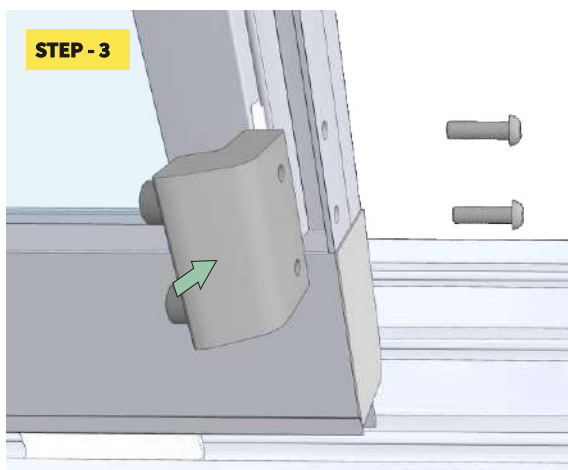

**STEP - 3**

*Washer stay in groove still, then inner stopper insert to other groove.*

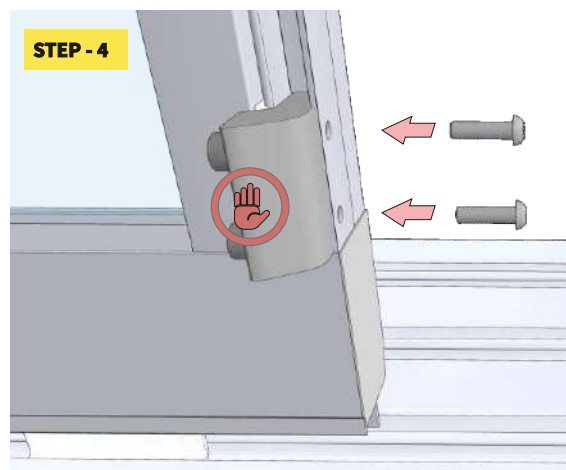

**STEP - 4**

*Secure the inner stopper to the segment with both bolts through the mentioned washer too!*

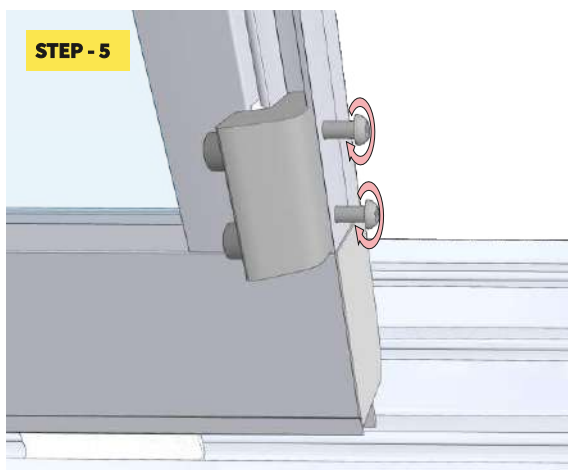

**STEP - 5**

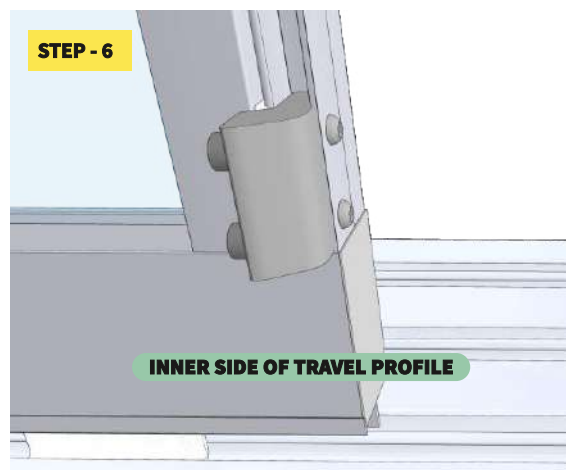

**STEP - 6**

**INNER SIDE OF TRAVEL PROFILE**

**STEP - 7**

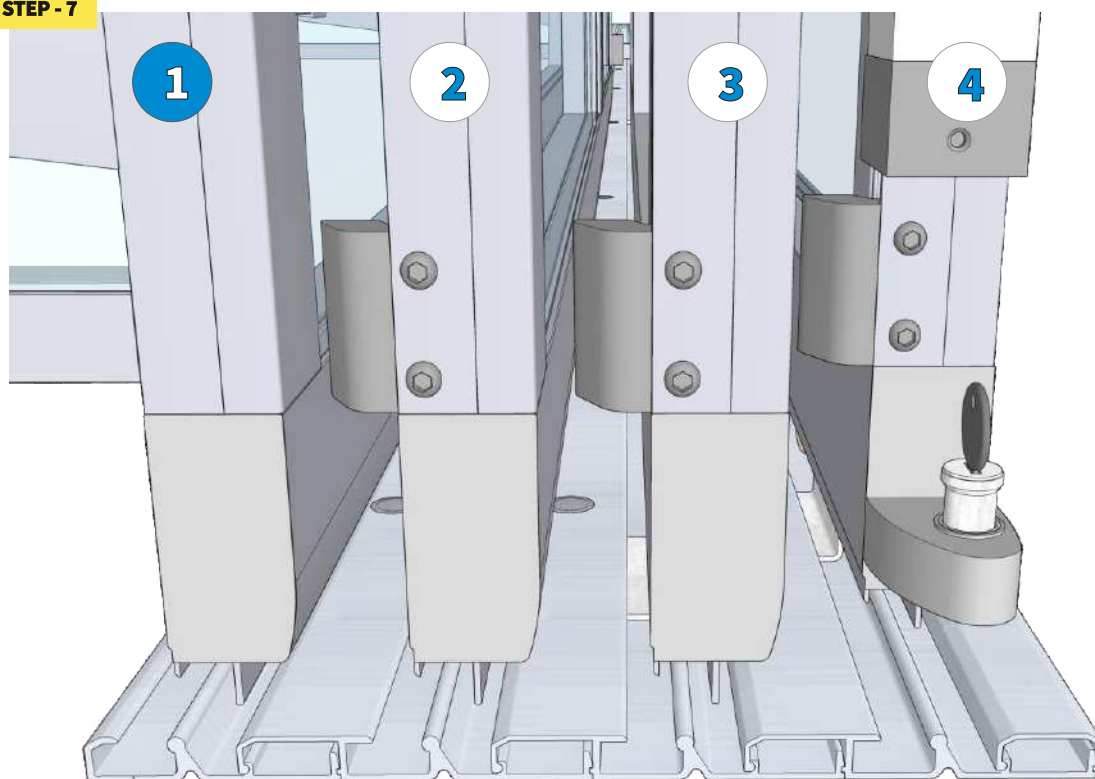

*Another inner stoppers to the revelant segments secure by both bolts through the mentioned washer again at same way!*

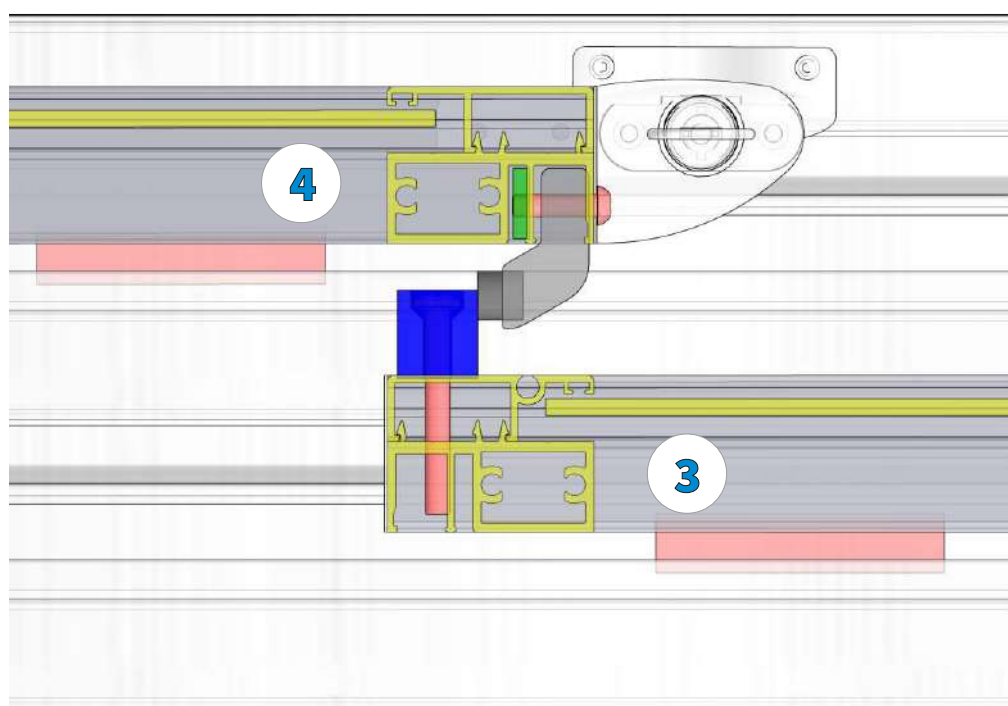

*An example of the principle of dependent segments ( situation btw segment nr.4 and nr.3 )*

Alukov®

ITEM

# COMPLETION THE FACES

---

ASSEMBLING INSTRUCTIONS FOR ENCLOSURES

## THE SEGMENTS ON THE RAILS / THE SMALLEST FACE

### STEP - 1

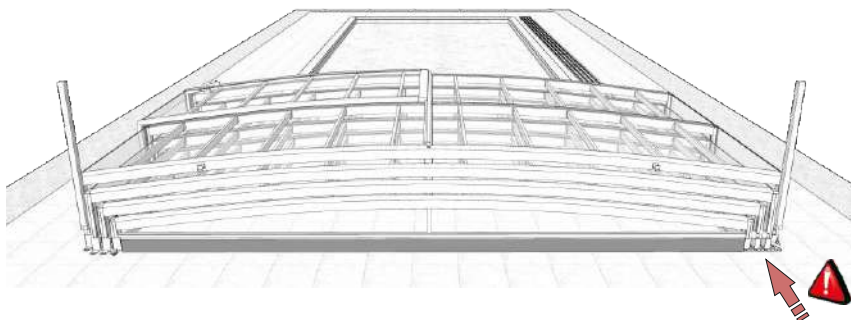

HERE RAIL IS WITHOUT ENDS OF THE RAIL STILL - SO THE SEGMENTS CAN DRIVE OUT FROM RAIL !

## THE SMALLEST FACE / CUT OF RUBBER

### STEP - 1.1

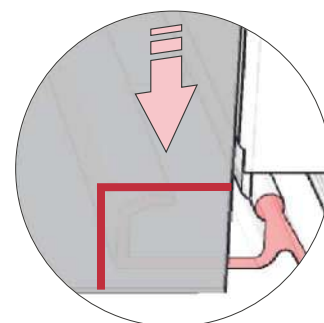
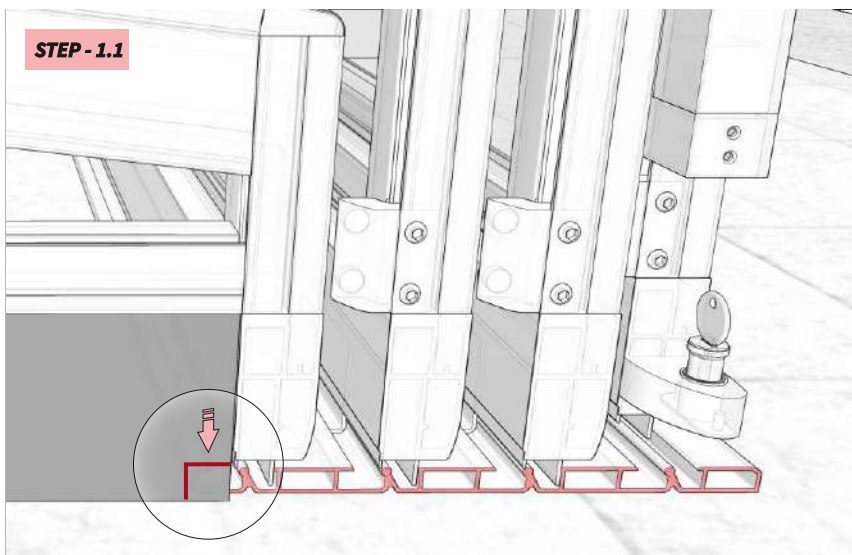

### RECOMMENDED TOOL

KNIFE

SCISSORS



### STEP - 1.2

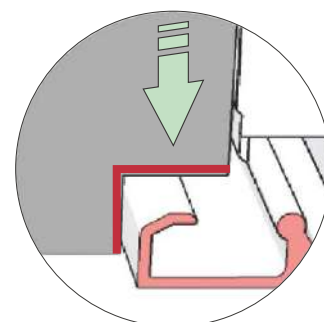
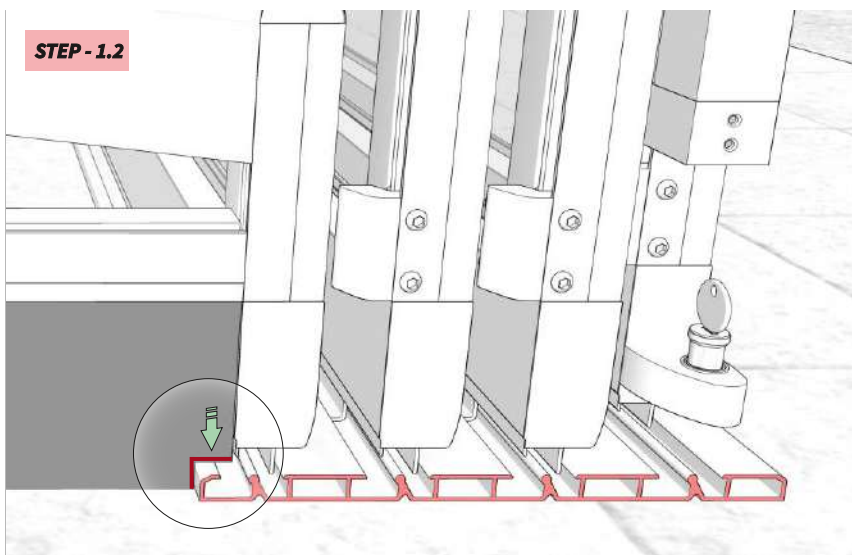

## THE SEGMENTS ON THE RAILS / THE LARGEST FACE

### STEP - 1

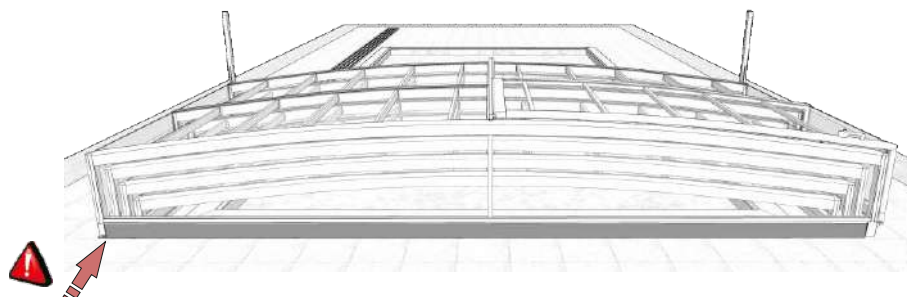

HERE RAIL IS WITHOUT ENDS OF THE RAIL STILL - SO THE SEGMENTS CAN DRIVE OUT FROM RAIL !

## THE LARGEST FACE / CUT OF RUBBER

### STEP - 1.1

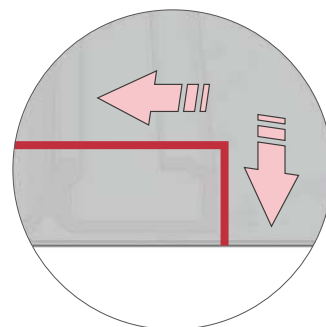
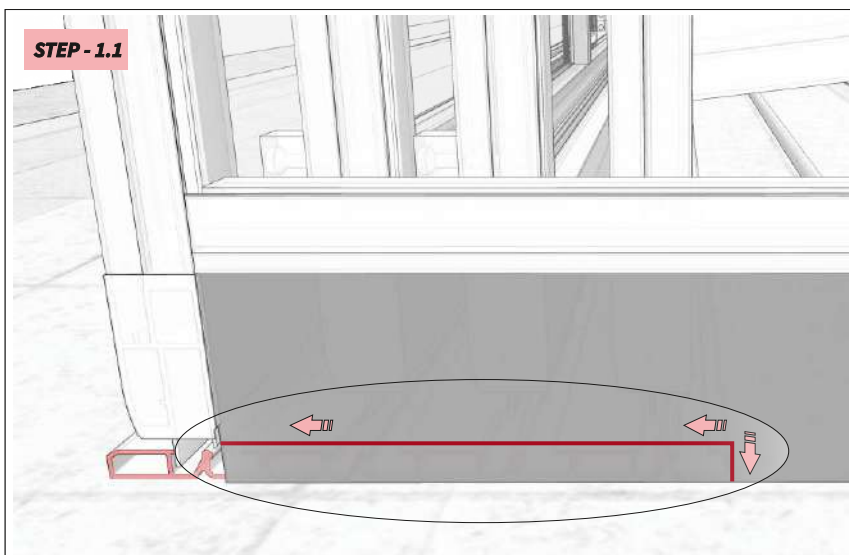

### RECOMMENDED TOOL

KNIFE

SCISSORS



### STEP - 1.2

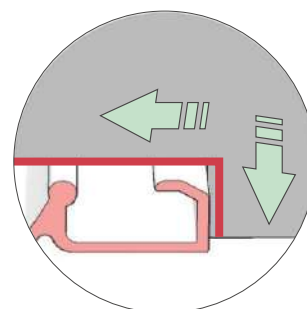
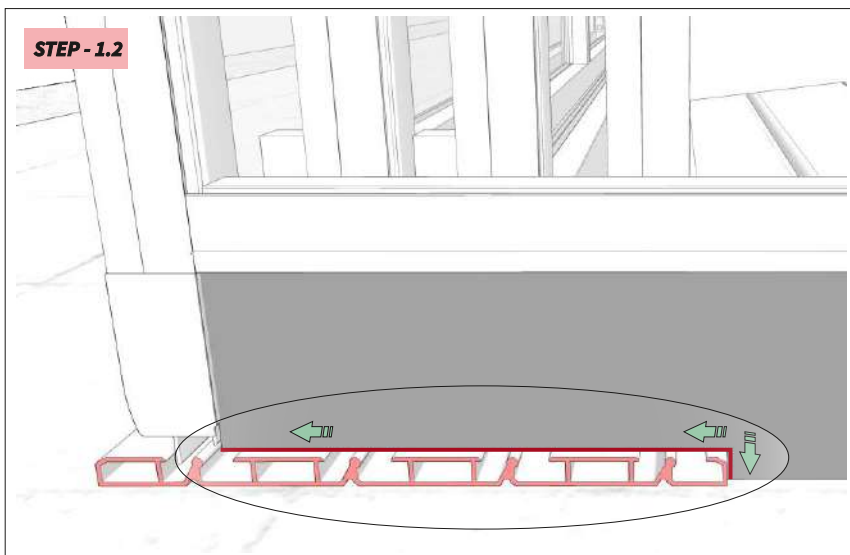

Alukov®

ITEM

**COMPLETATION THE RAIL**  
**( PARKING FOR ALL SEGMENTS - POSITION )**

---

ASSEMBLING INSTRUCTIONS FOR ENCLOSURES

## COMPLETION THE RAIL / PARKZONE FOR ALL SEGMENTS

- FIXING THE PLASTIC BACKSTOPS FOR ABSORB THE SHOCK OF TRAVEL AND DEFEND FOR REFUSE TO START OF SEGMENTS FROM RAILS
- FIXING AN END OF RAIL AVOID MOVING THE SEGMENTS OFF THE RAILS.

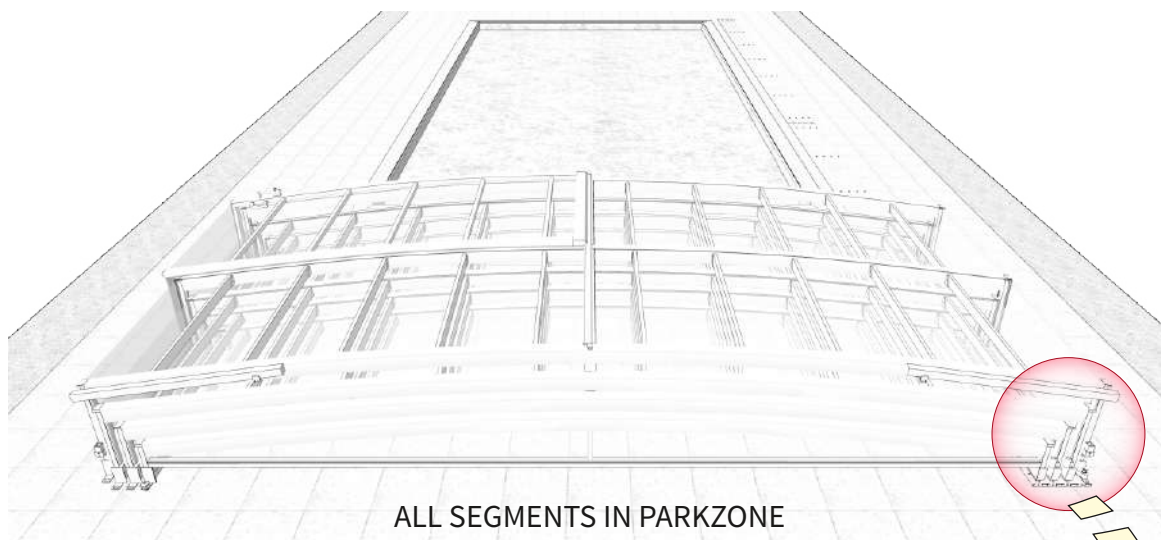

ALL SEGMENTS IN PARKZONE

## PARKZONE / FINALIZATION THE RAIL

### THE PLASTIC BACKSTOP



### THE RAIL ENDING PARTS

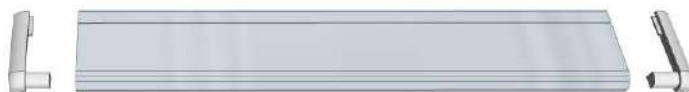

### FIX MATERIAL



### RIVET 4x10 mm A2

- 1 pce PLASTIC BACKSTOP = ( 2 pce for join into single rail of each segment )
- 1 pce RAIL ENDING PART = ( number of rivets according to number of segments + always an one rivet at more )



**SETTING OF CORRECT POSITION FOR THESE PARTS IN PARKZONE SHOWN ON FOLLOWING PAGES !**

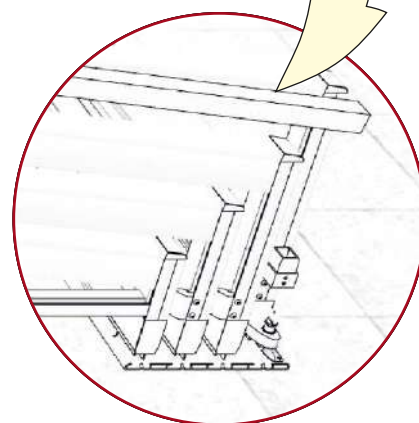

**SIDE - WHEELS FOR RAIL**



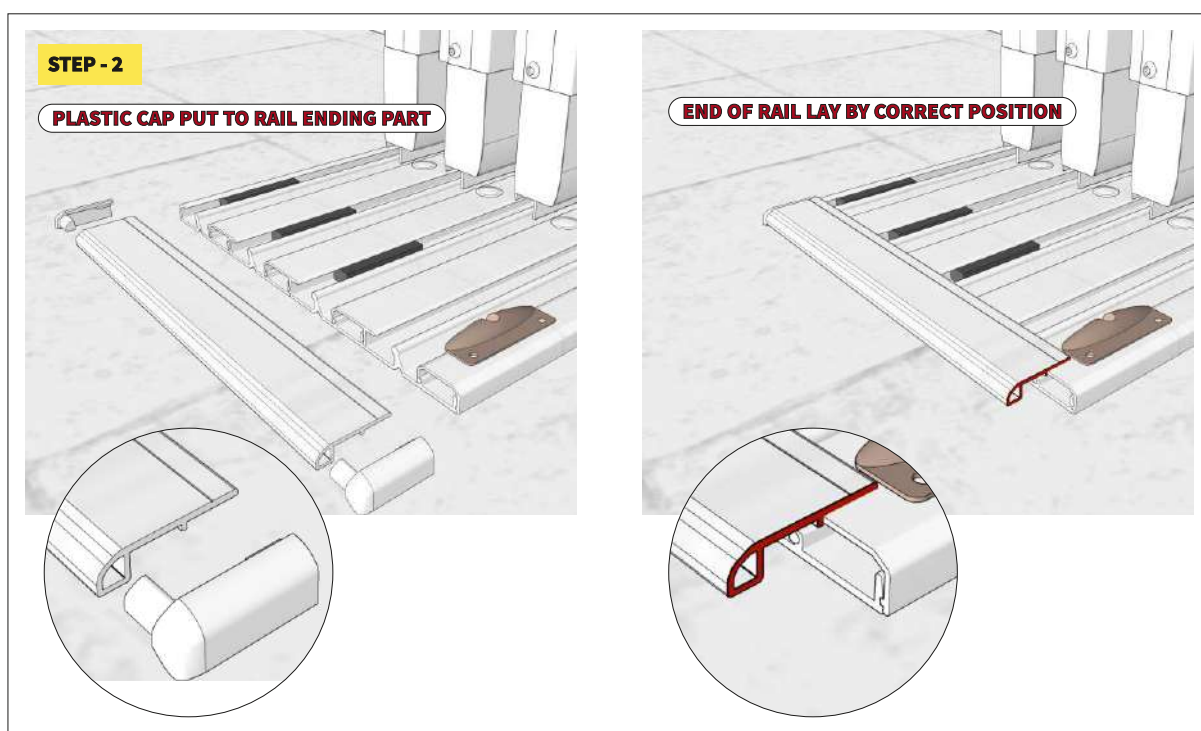
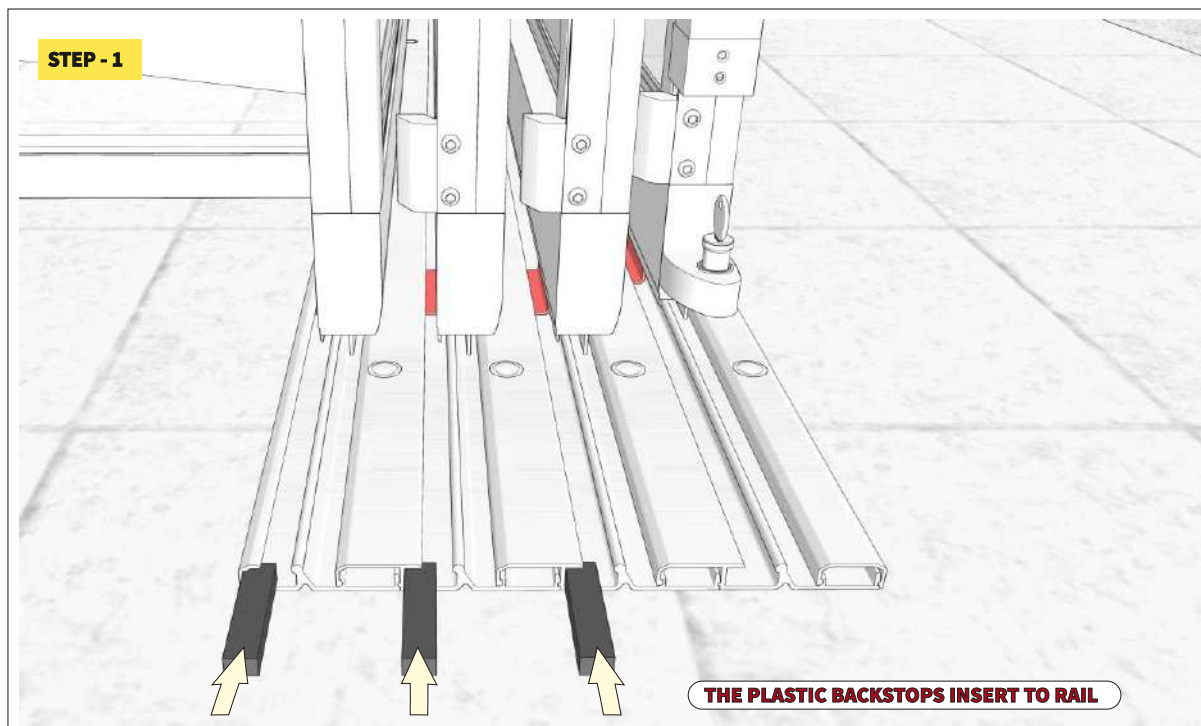

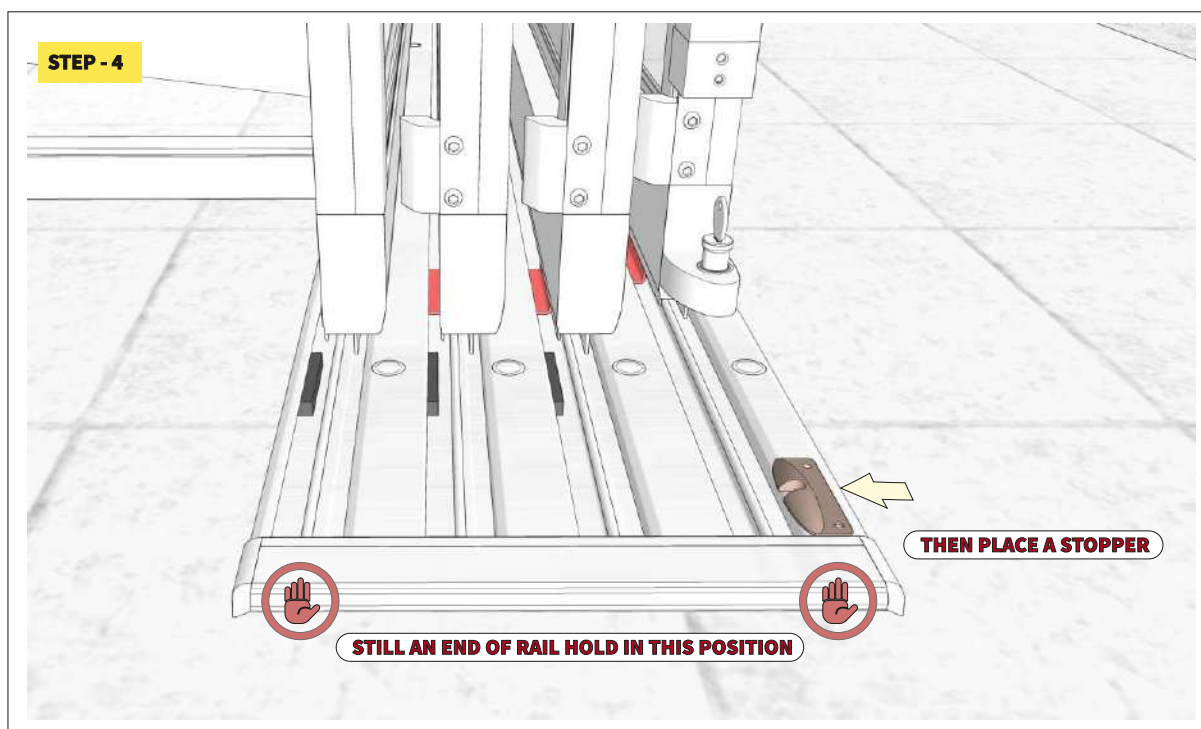
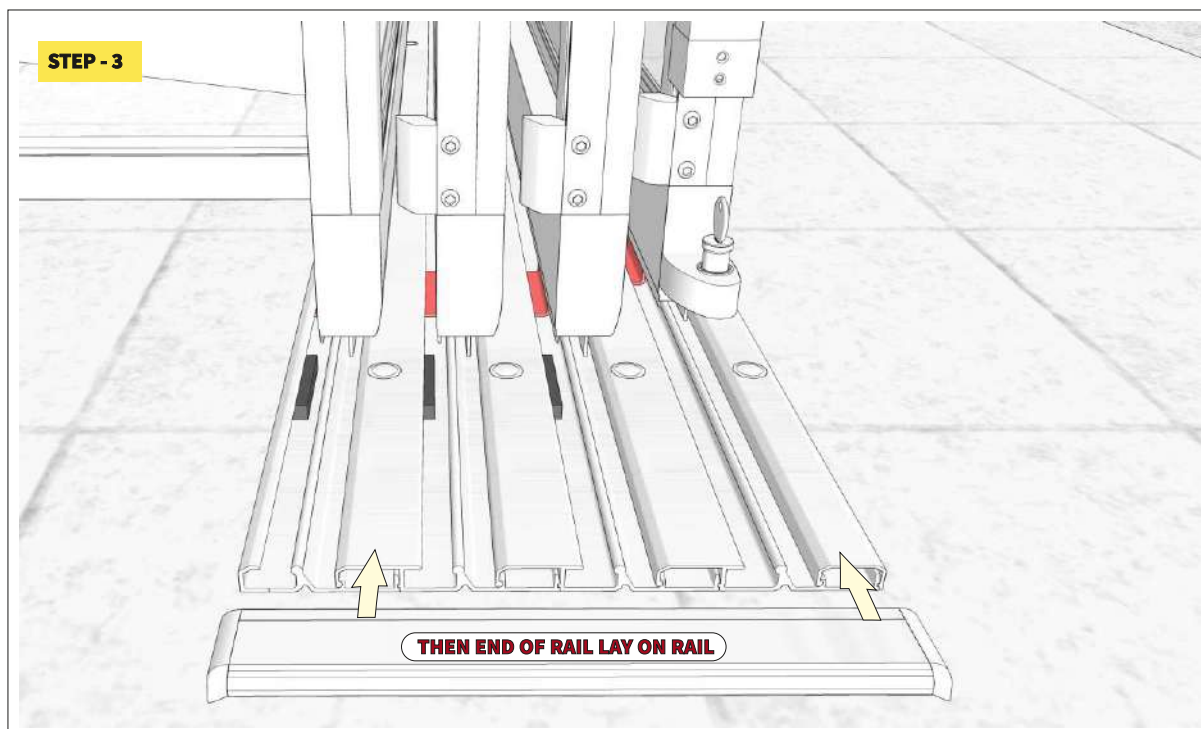

**STEP - 5**

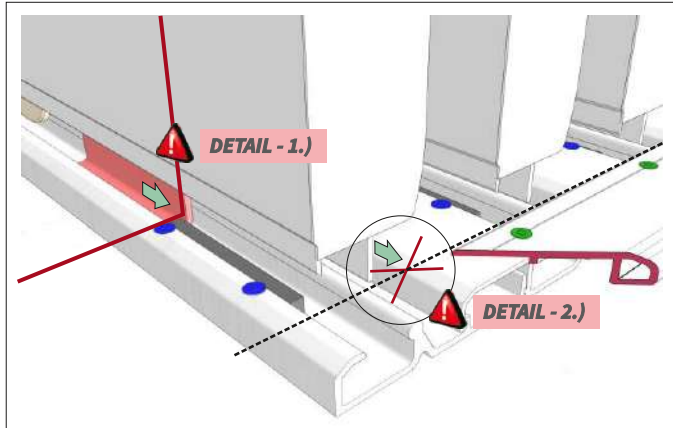
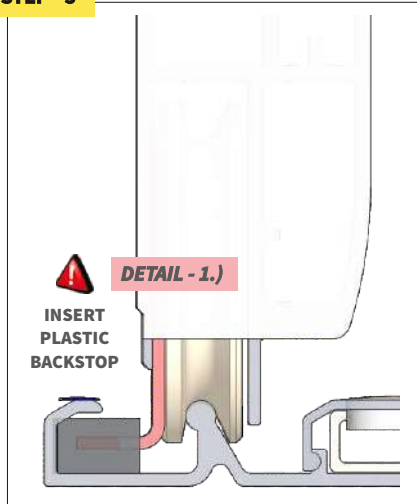

**EACH PLASTIC BACKSTOP PUSH INWARD TO FACE OF RAIL AND FIX IT TO THE RAIL BY RIVET.**

**SETTING THE CORRECT POSITION OF EACH STOP MUST MEET THE REQUIREMENT - PREVENT THE IMPACT OF THE TRAVEL TO THE END OF THE TRACK.**

**STEP - 6**

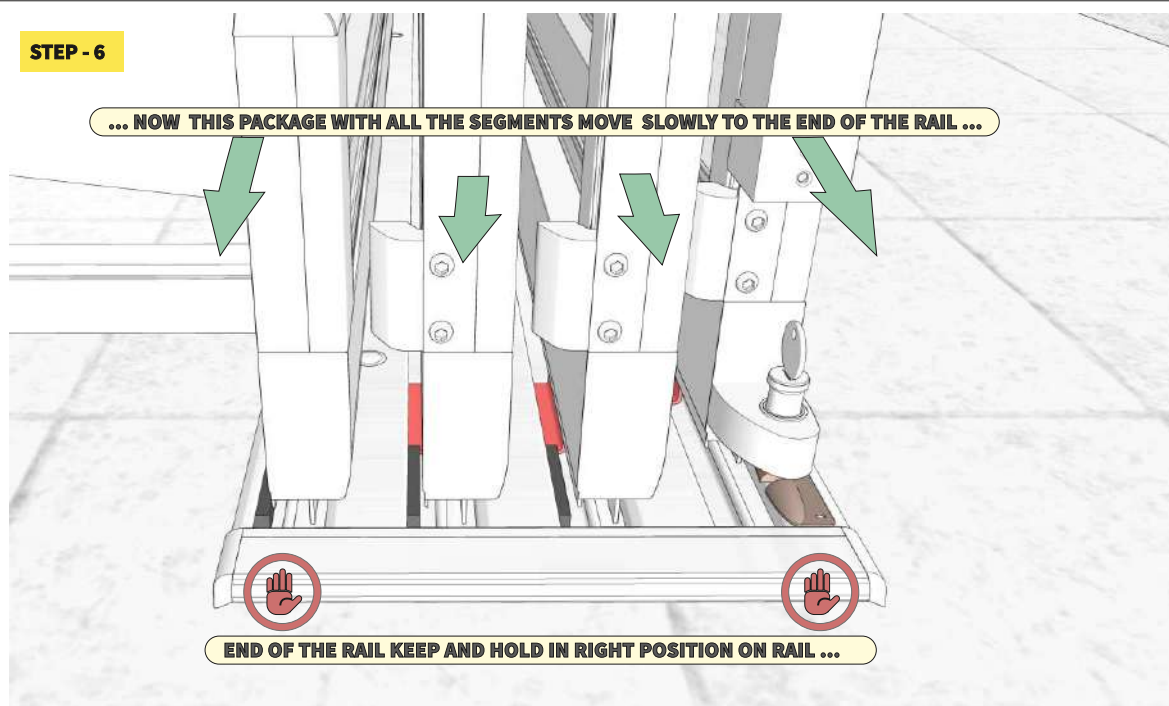

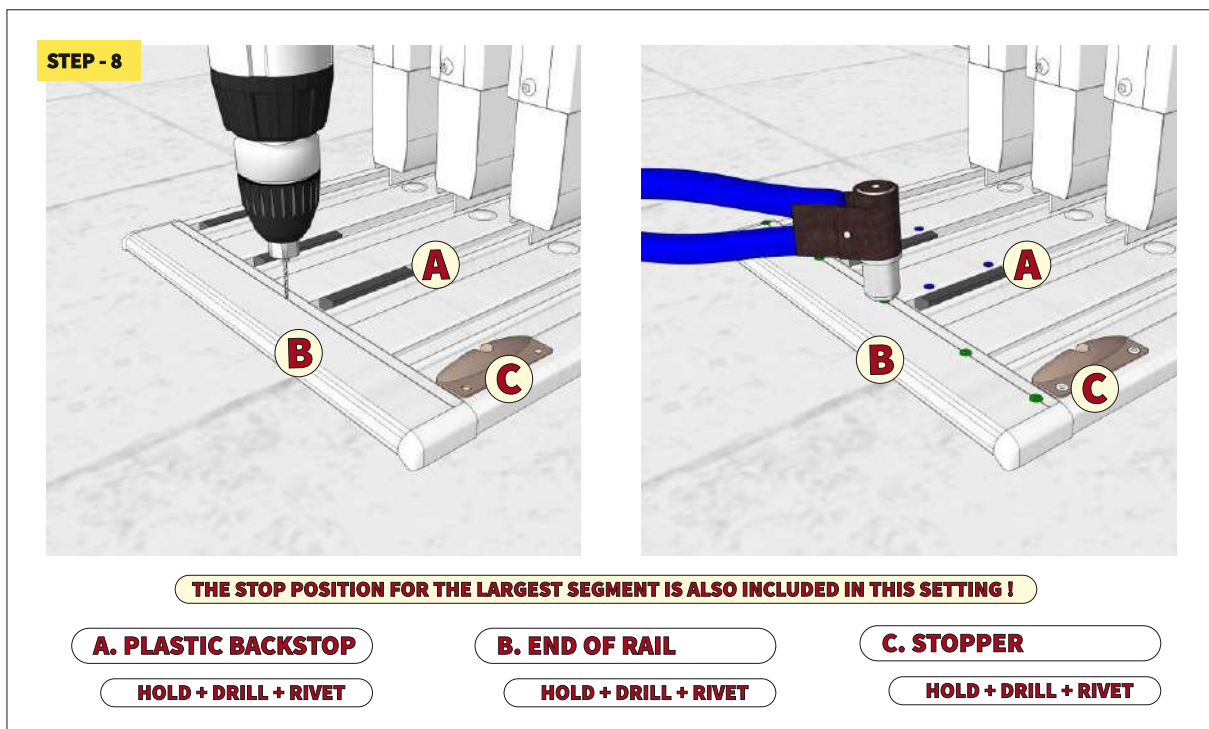
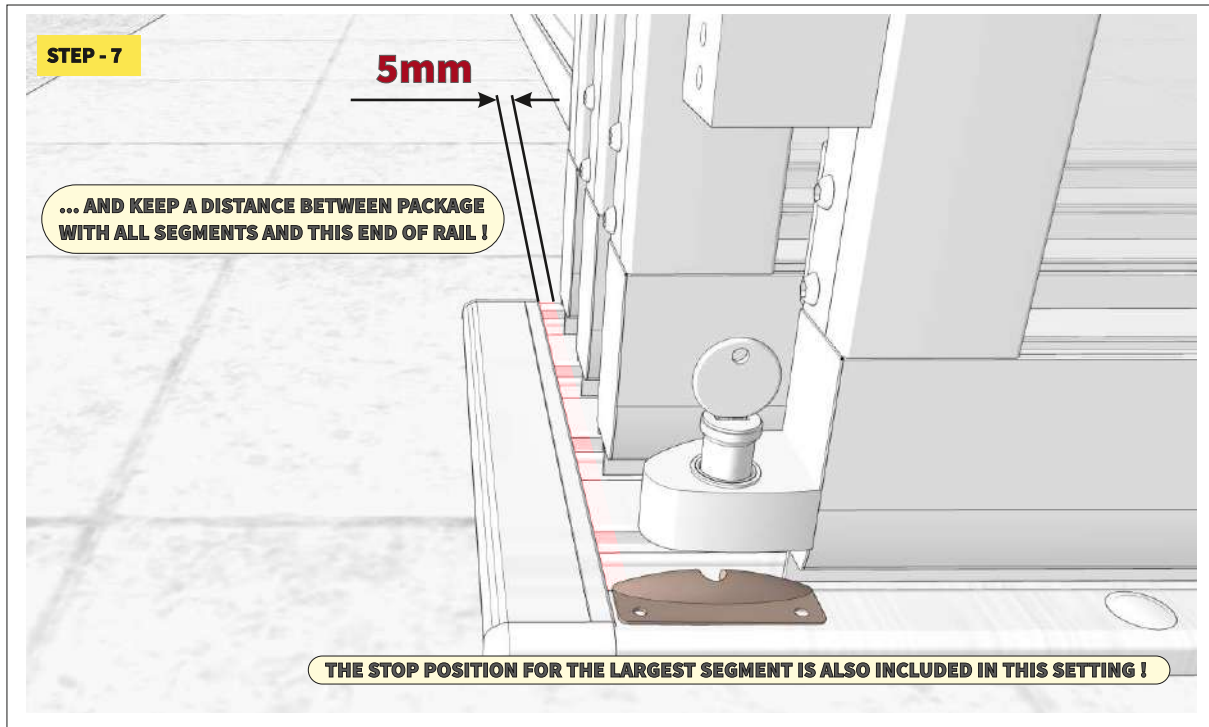

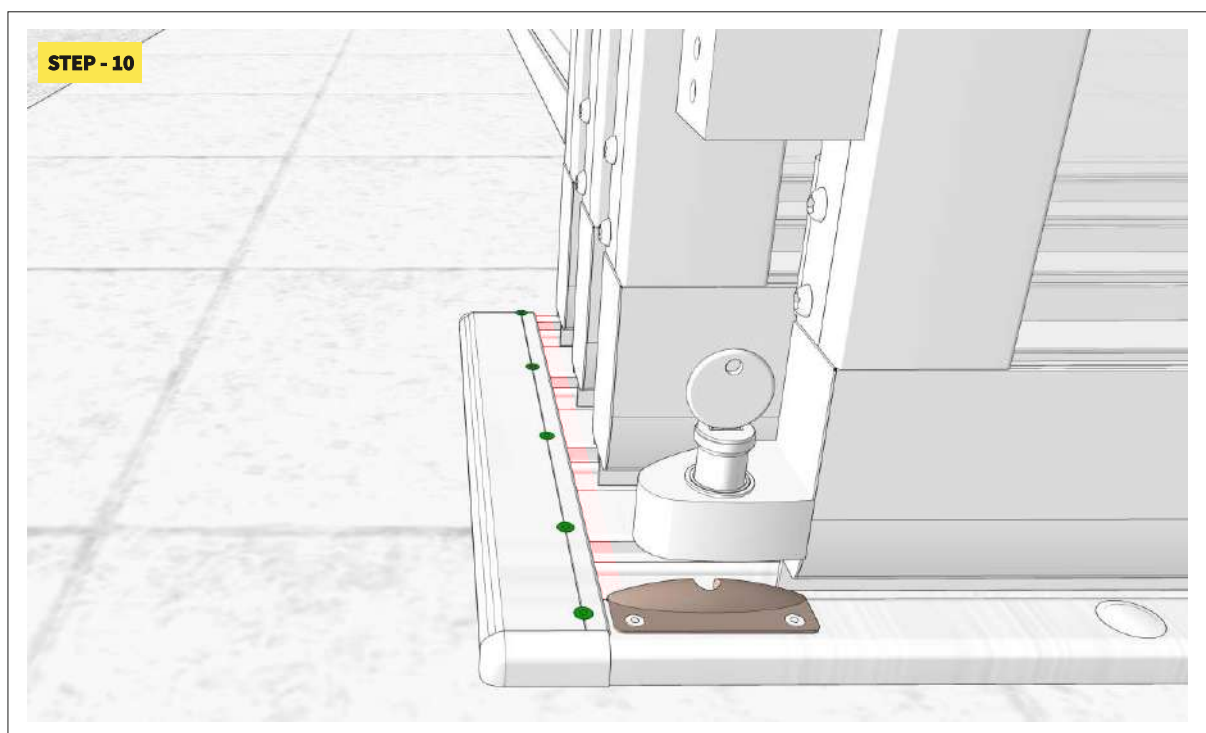
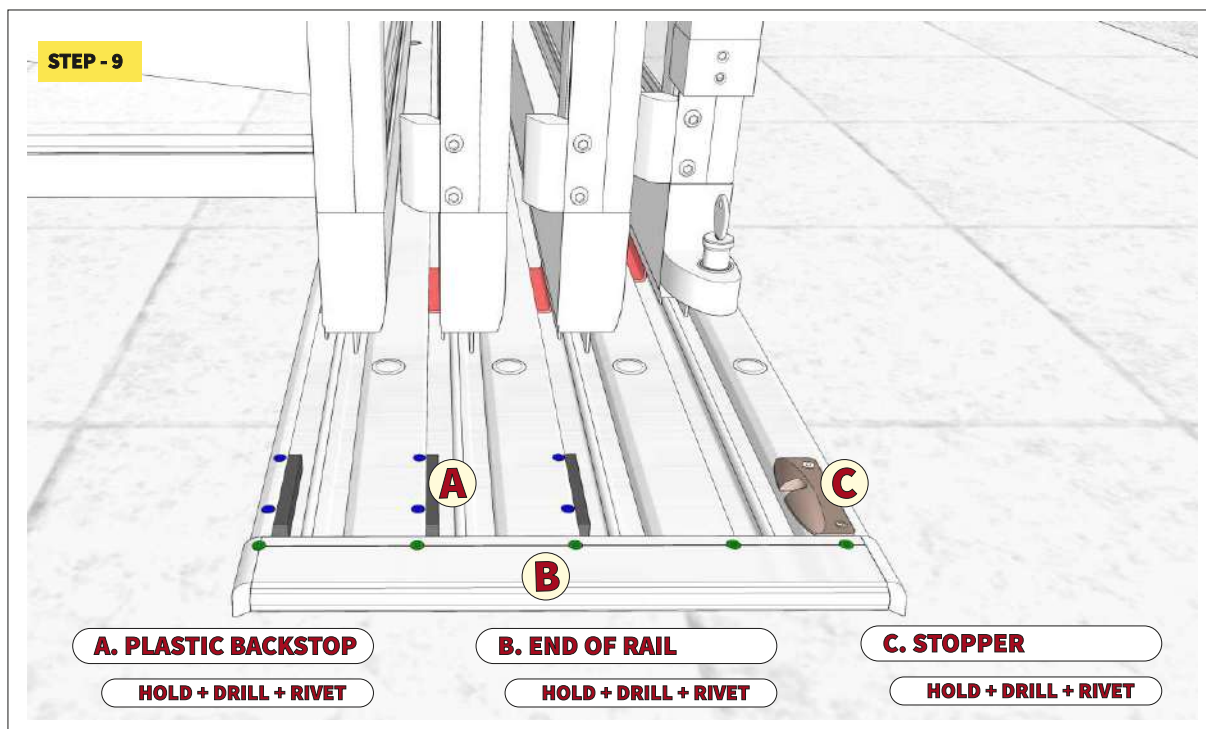

## CORRECT FIX OF THE RAIL ENDING PARTS WITH PLASTIC BACKSTOPS / PARKZONE

**PACKAGE ( THE LARGEST SEGMENT + OTHER SEGMENTS ) STOPPED IN PARKZONE - MAXIMAL SPACE FOR USE OF THE POOL.**

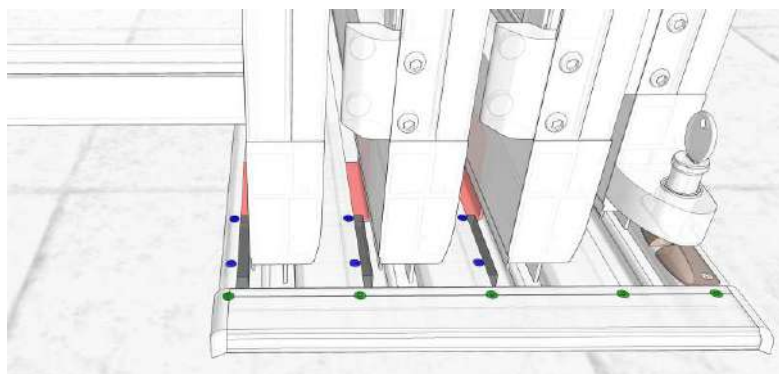

**PARKZONE  
FOR  
ALL SEGMENTS**

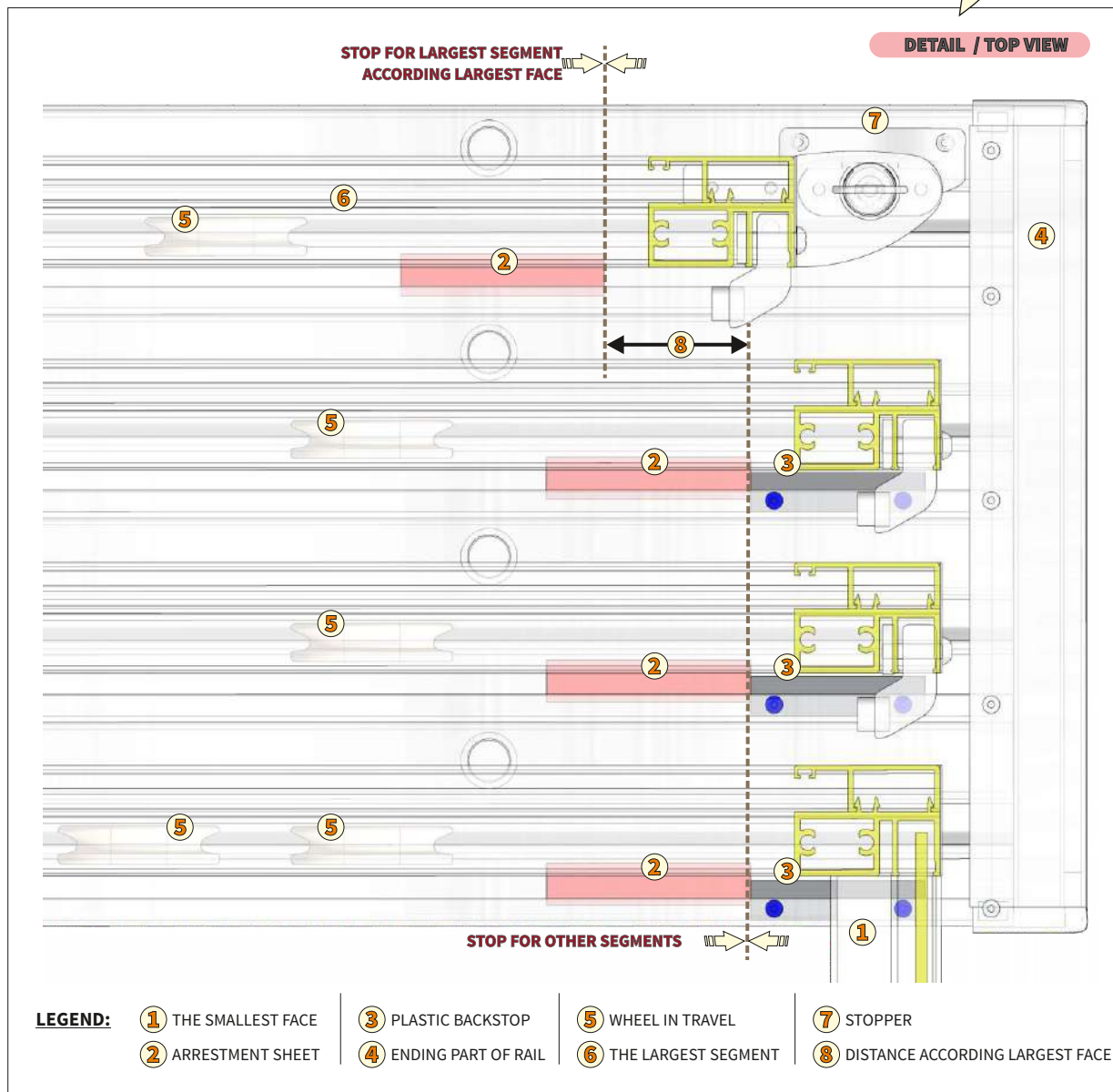
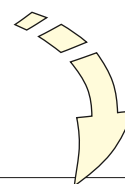



ITEM

**COMPLETATION THE RAIL**  
**( COVER CLOSED - POSITION )**

---

ASSEMBLING INSTRUCTIONS FOR ENCLOSURES

## COMPLETION THE RAIL / COVER CLOSED

- FIXING THE PLASTIC BACKSTOP FOR ABSORB THE SHOCK OF TRAVEL AND DEFEND FOR REFUSE TO START OF LARGEST SEGMENT FROM RAILS
- FIXING AN END OF PART AVOID MOVING THE LARGEST SEGMENT OFF THE RAILS.

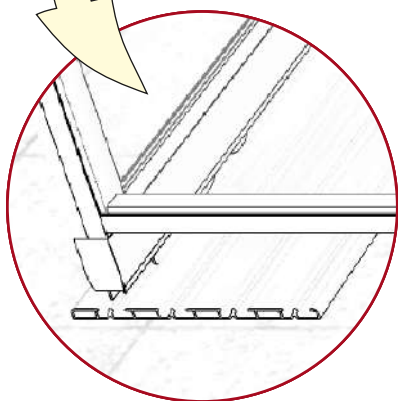
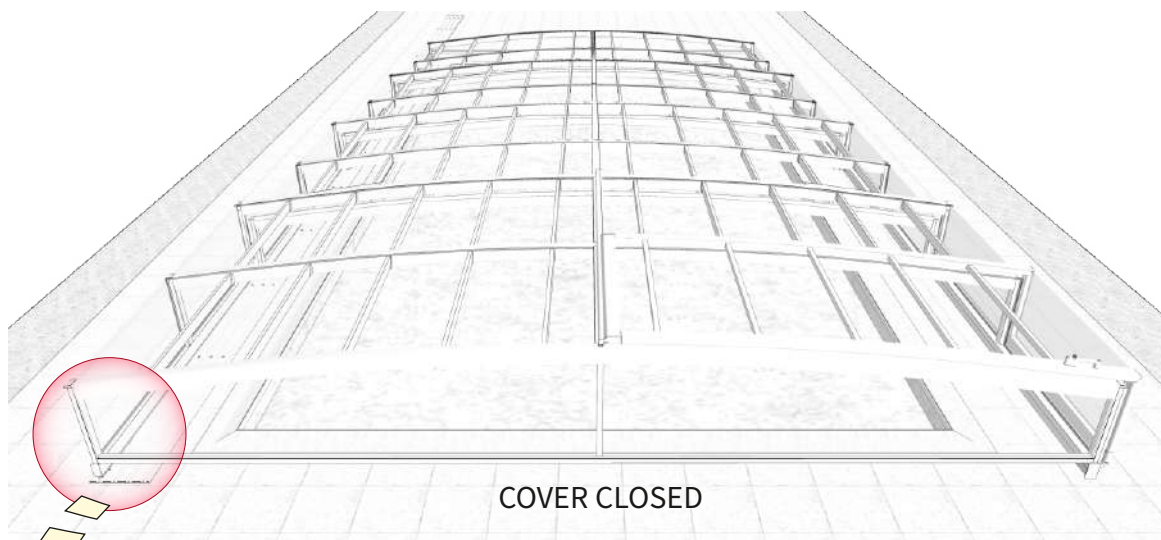

## COVER CLOSED / FINALIZATION THE RAIL

### THE PLASTIC BACKSTOP



### THE RAIL ENDING PARTS

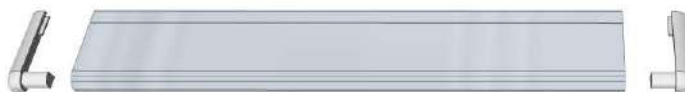

### FIX MATERIAL



### RIVET 4x10 mm A2

- 1 pce PLASTIC BACKSTOP = ( 2 pce for join into single rail of each segment )
- 1 pce RAIL ENDING PART = ( number of rivets according to number of segments + always an one rivet at more )



**SETTING OF CORRECT POSITION FOR THESE PARTS WHEN COVER CLOSED ACCORDING TO FOLLOWING PAGES !**

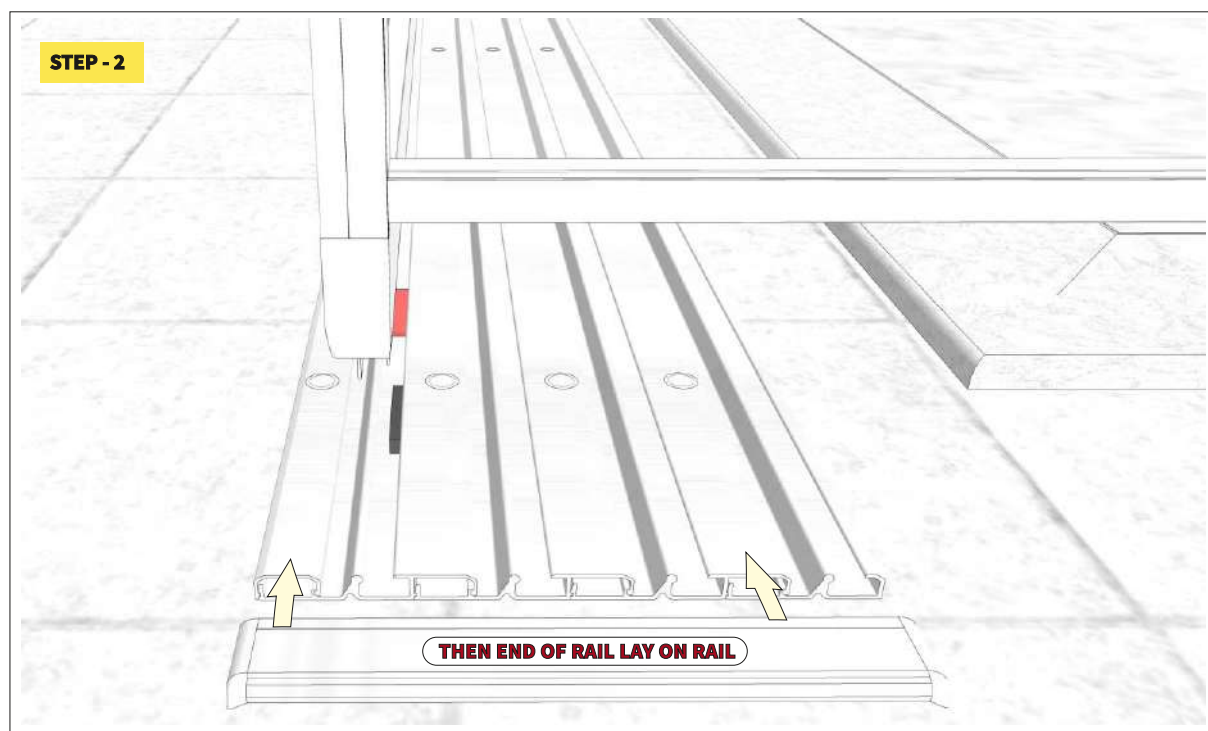
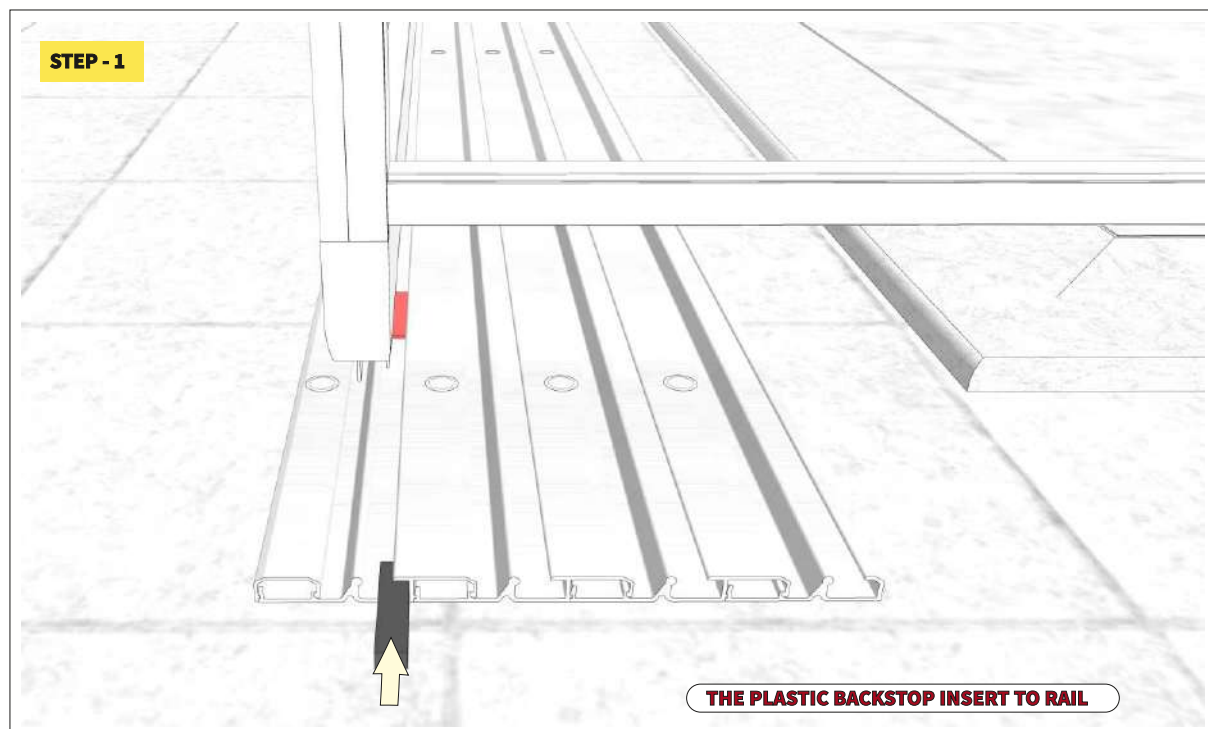

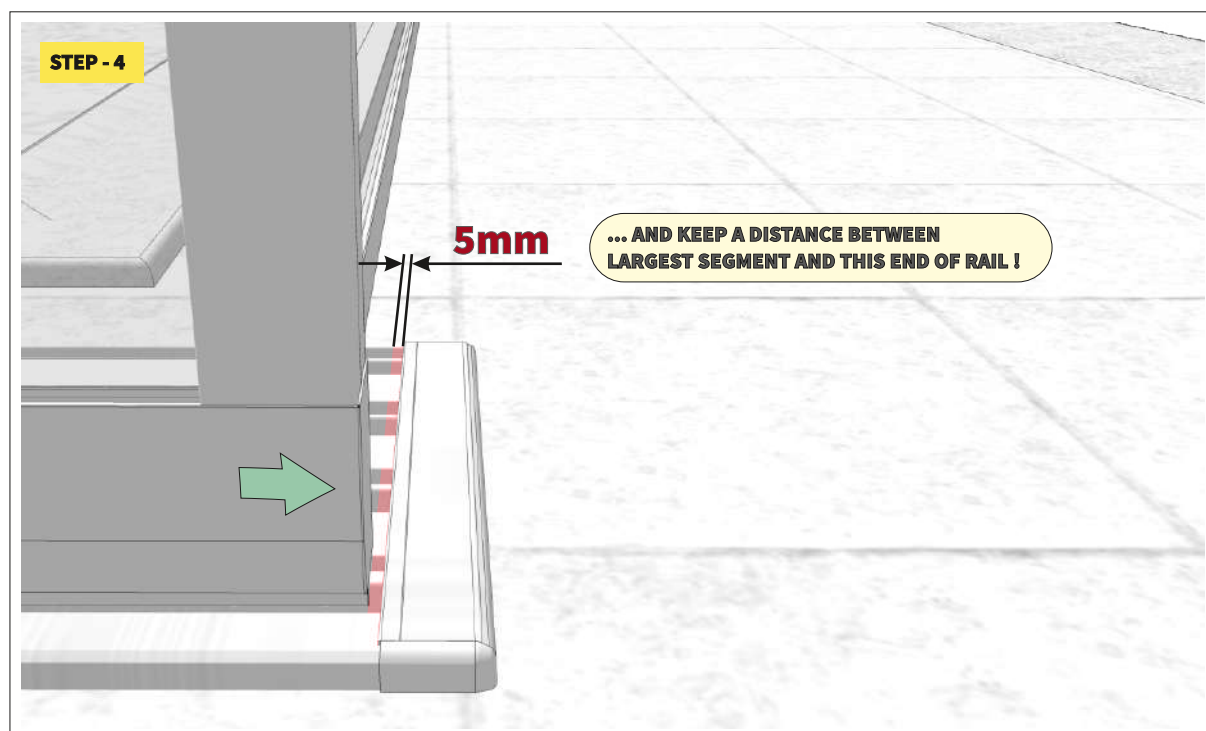
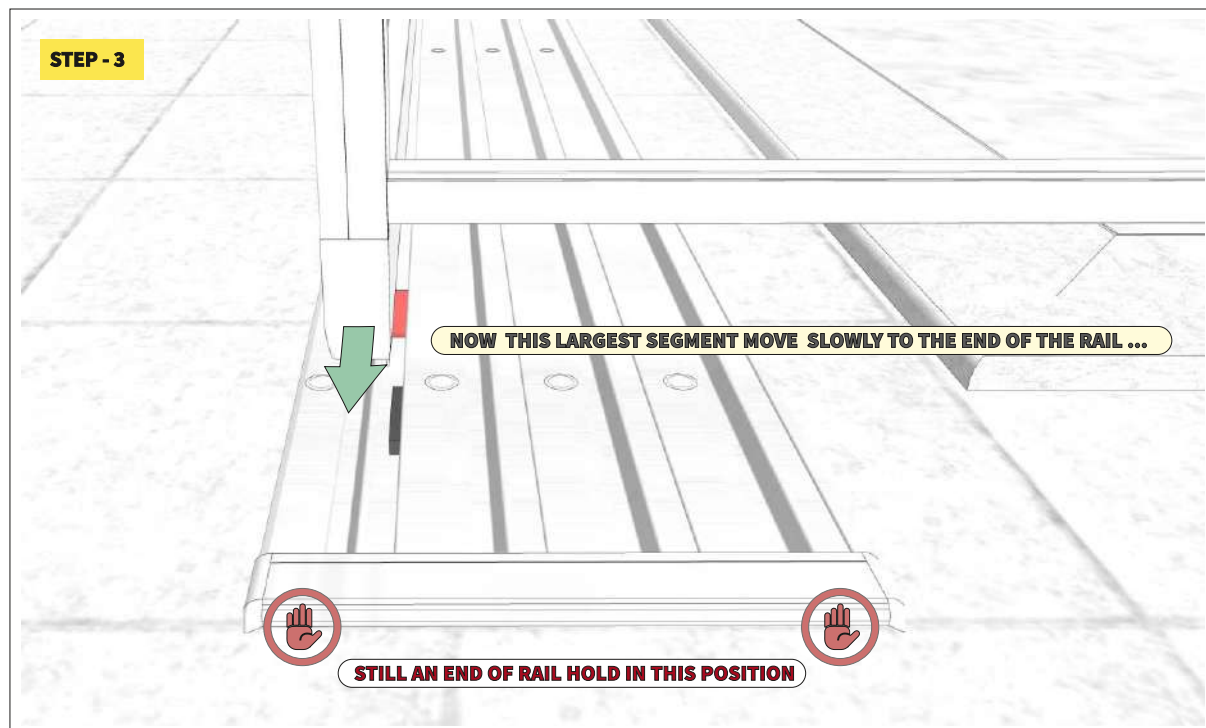



## **STOPPER FOR LOCK ARRESTMENT OF SEGMENT**

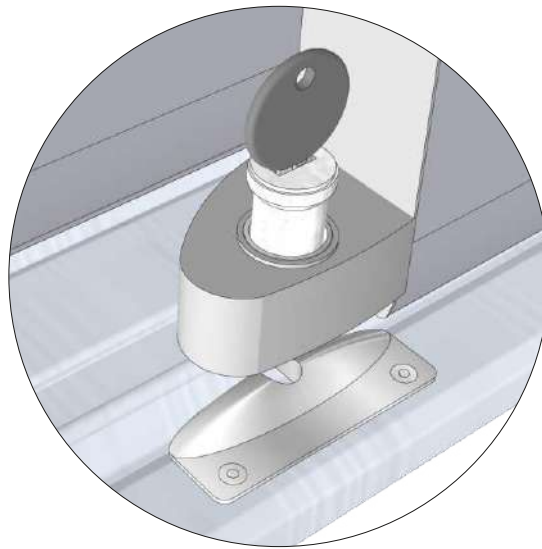

### **THE DEPENDENT SEGMENTS**

**STOPPER - FOR LARGEST SEGMENT ONLY**  
*( the largest segment is overlapping  
with descending segment )*



### **THE INDEPENDENT SEGMENTS**

**STOPPER - FOR EACH SEGMENT**  
*( each ascending segment is overlapping  
with descending segment )*

ITEM

# STOPPER FOR ARRESTMENT

## LOCK ARRESTMENT / STOPPER - NUMBER BY SEGMENT TYPE

### THE DEPENDENT SEGMENTS

**STOPPER - FOR LARGEST SEGMENT ONLY (the largest segment is overlapping with descending segment)**

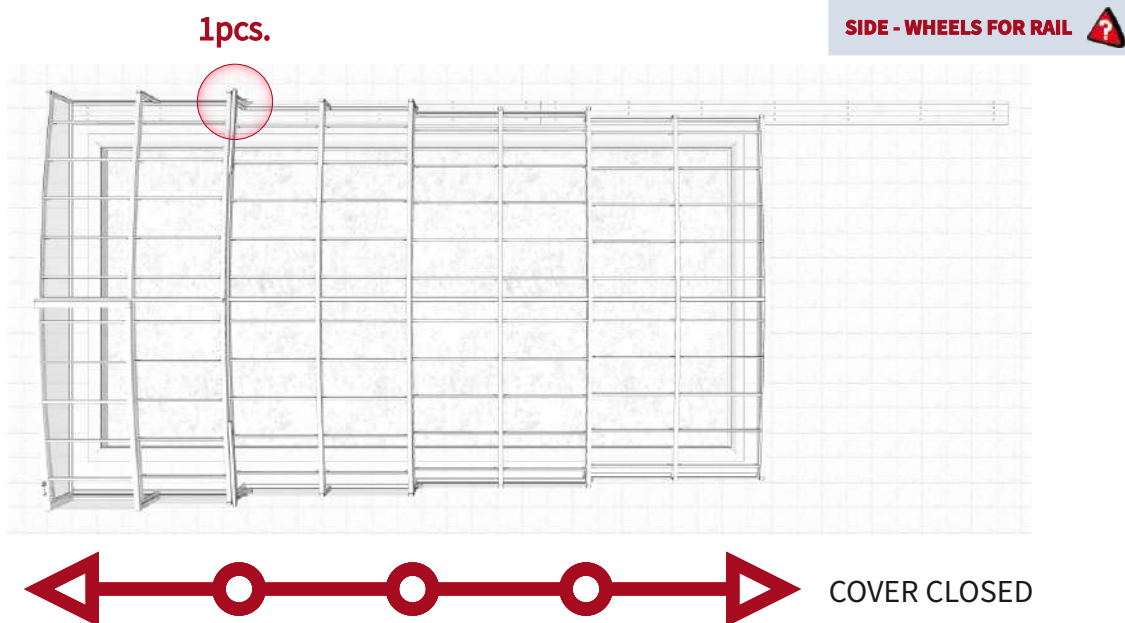

### THE INDEPENDENT SEGMENTS

**STOPPER - FOR EACH SEGMENT (each ascending segment is overlapping with descending segment)**

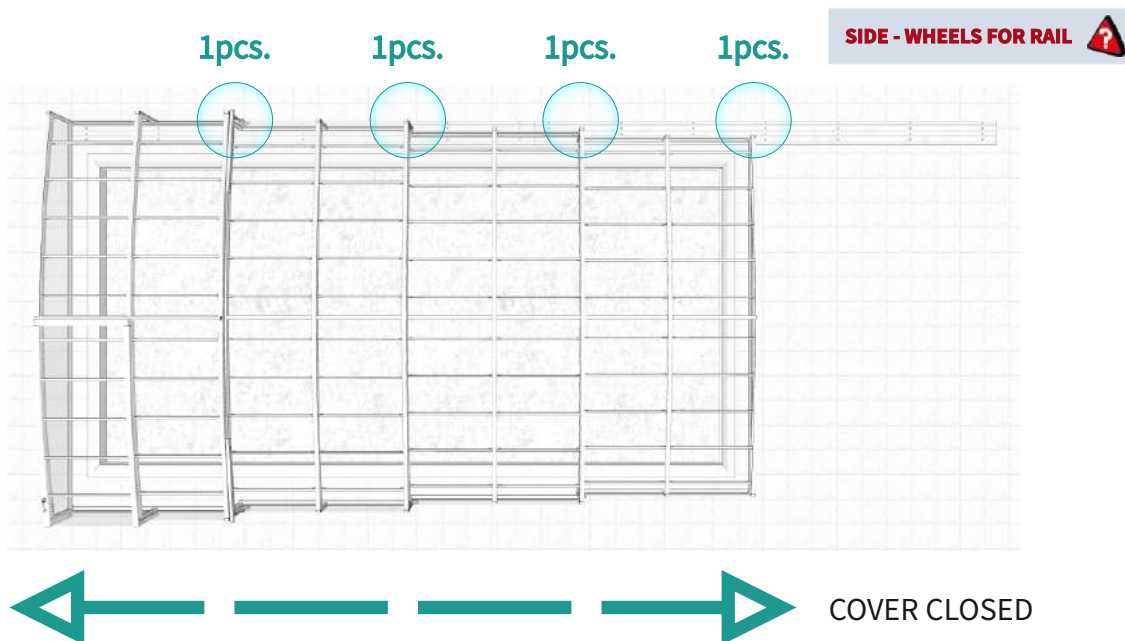

## LOCK ARRESTMENT - CONTROL

### STEP - 1

MODE UNLOCK

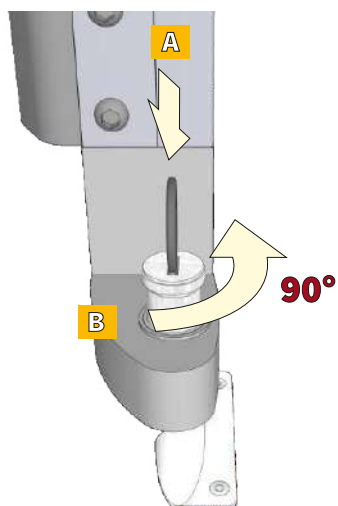

**A)** - take the needed key put the key in the lock hole

**B)** - after putting in turn the key by 90°

### STEP - 2

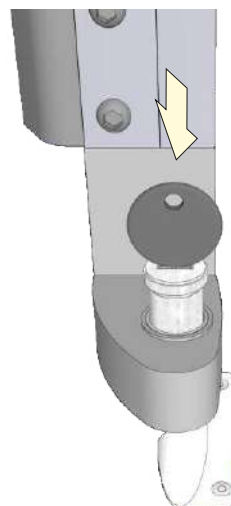

After turning the key by 90° push downwards until stop

### STEP - 3

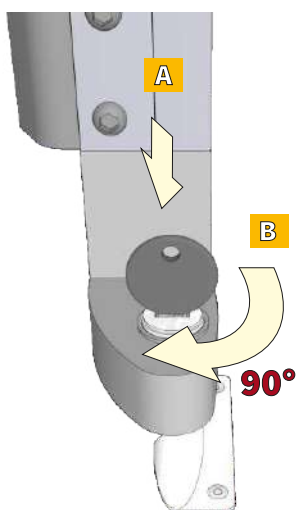

**A)** - stop and holding of this position

**B)** - turn the key back by 90°

### STEP - 4

MODE LOCK

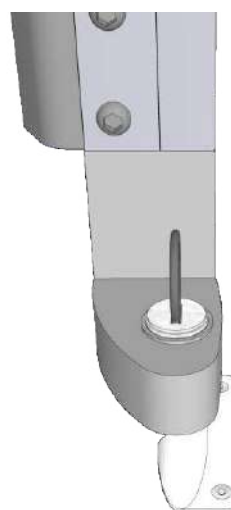

### ARRESTMENT-LOCK

is locked and segment is ensured !

Unlocking of arrestment is opposite way of these steps !

## LOCK ARRESTMENT - SETTING

### THE GENERAL INSTRUCTION

NOTHING NEEDS TO BE SET HERE = MOSTLY THE LENGTH OF THE LOCK-PINS  
COULD TO HAVE SUFFICIENT LENGTHS FROM FACTORY.

THESE LENGTHS ARE POSSIBLE TO CHECK IN PRACTICE,  
ON WORKPLACE ACCORDING TO THE INSTRUCTIONS ON THIS PAGE.

#### STEP - 1

MODE UNLOCK

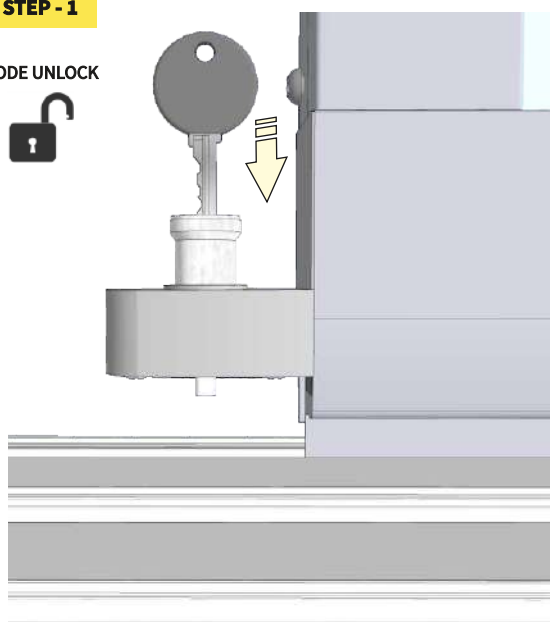

#### STEP - 2

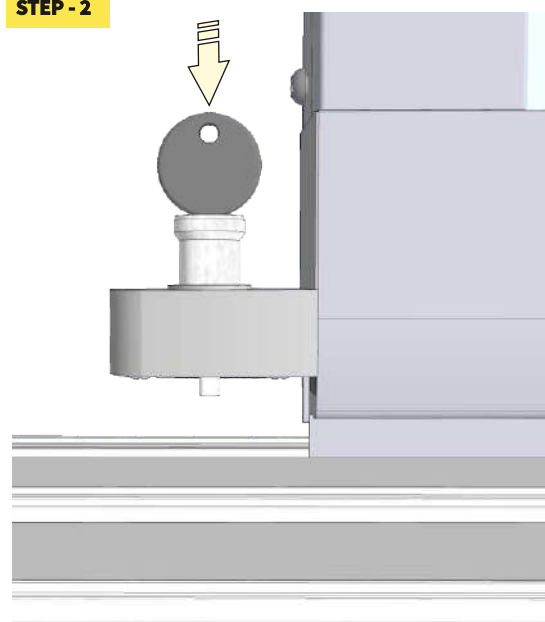

#### STEP - 3

MODE LOCK



CHECK A LENGTH  
OF LOCK-PIN

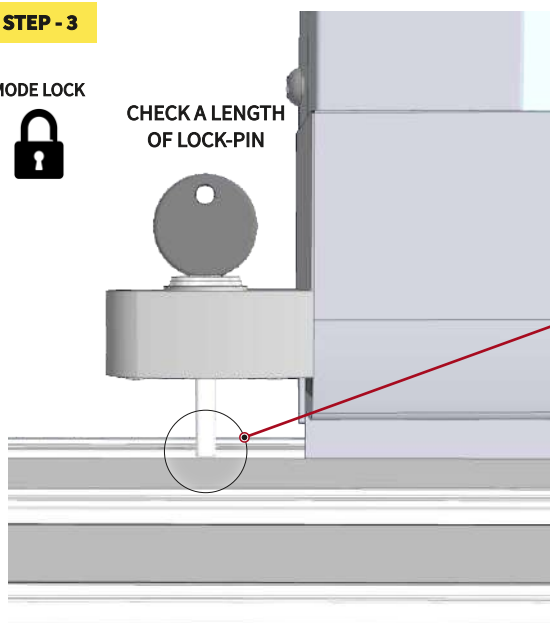

#### STEP - 3 (DETAIL)

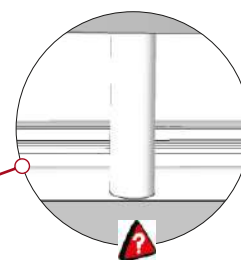

**LENGTH OF LOCK-PIN IN MODE LOCK IS OK, IF:**

- THE LOCK-PIN DID NOT BUMP TO SURFACE OF THE RAIL DURING LOCKING OF THIS ARRESTMENT.
- THE SEGMENT DID NOT LIFT AFTER LOCKING OF THIS ARRESTMENT.
- LENGTH OF LOCK-PIN IS SUFFICIENT FOR SNAP DOWN INTO STOPPER.  
(this point of check make during fixing of the stopper to rails)

## STOPPER FOR LOCK ARRESTMENT - FIX TO ONE RAIL

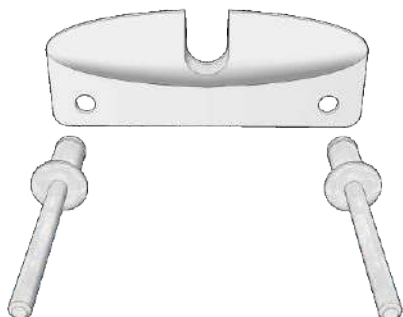

### COMPONENT

**EACH STOPPER  
( ARRESTMENT OF SEGMENT )**

### FIX MATERIAL

**RIVET 4x10 mm A2 ( 2 pce )**



**SETTING OF CORRECT POSITION FOR STOPPERS - ACCORDING TO OVERLAPPING OF ALL SEGMENTS WHEN COVER CLOSED !**

### STEP - 1

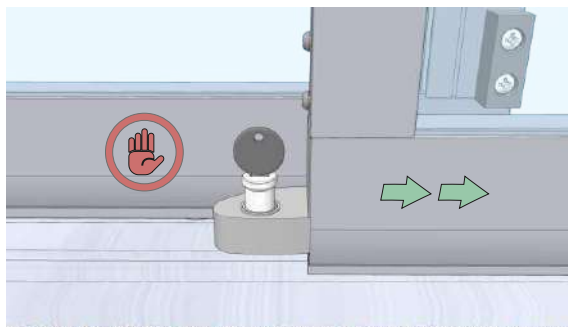

### STEP - 2

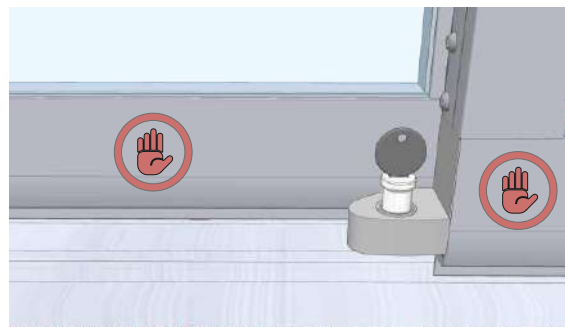

### STEP - 3

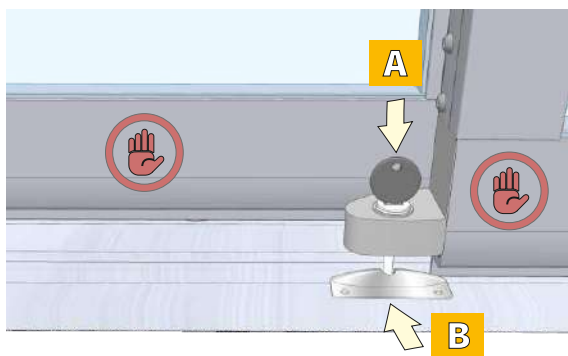

The stopper must stop of moving segment safely, so the centre of stopper (B) against arrestment peg must be maximal in position - LOCKED (A).

### STEP - 4

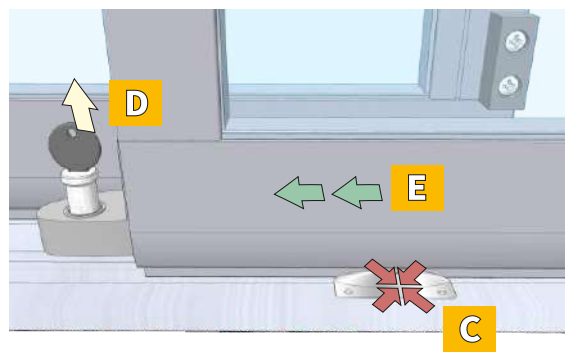

Now hold this stopper securely in position (C) and adjust an arrestment to the position - UNLOCKED (D), after maybe moving with segment away (E) for easily drilling according to stopper.

**STEP - 4 (DETAIL)**

*The segments must not hit to stopper during movable with them.*



**STOPPER MUST NOT BE AN OBSTACLE AGAINST TRAVEL PROFILE OF SEGMENT !**

**STEP - 5**

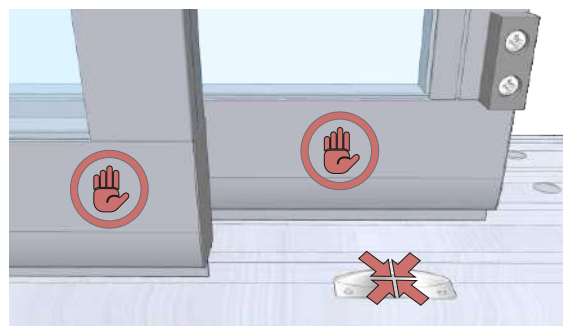

**STEP - 6**

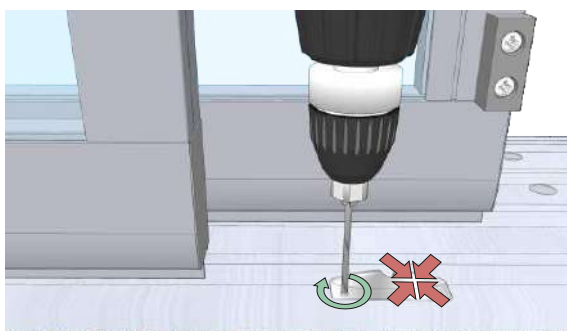

Hold the stopper securely when drilling into the rail - use the appropriate drill bit for the size of the rivet.

**STEP - 7**

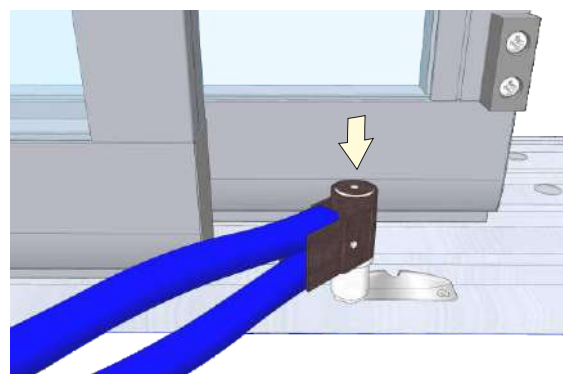

Stopper can fix to rail by help with 2 rivets

**STEP - 8**

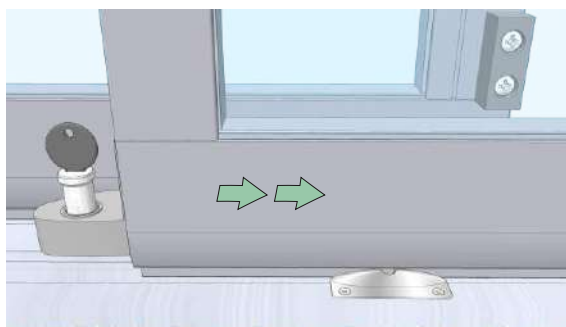

**STEP - 9**

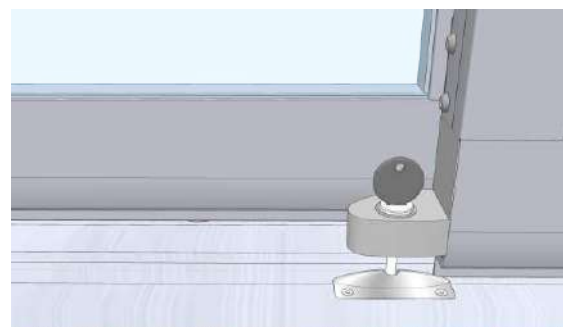

## **SIDE ARRESTMENT OF SEGMENT**

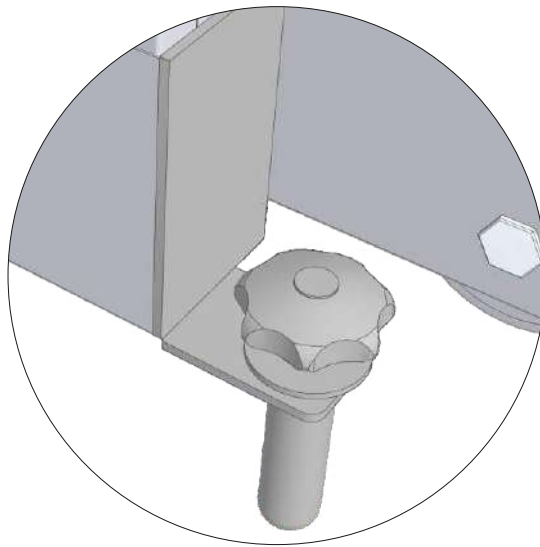

### **THE DEPENDENT SEGMENTS**

**SIDEARRESTMENT - FOR EACH SEGMENT**  
*( each ascending segment is overlapping with  
descending segment )*



### **THE INDEPENDENT SEGMENTS**

**SIDEARRESTMENT - FOR EACH SEGMENT**  
*( each ascending segment is overlapping with  
descending segment )*

ITEM

# SIDE ARRESTMENT

## SIDE ARRESTMENT / BOTH PARTS - NUMBER BY SEGMENT TYPE

### THE DEPENDENT SEGMENTS

**SIDEARRESTMENT - FOR EACH SEGMENT (each ascending segment is overlapping with descending segment)**

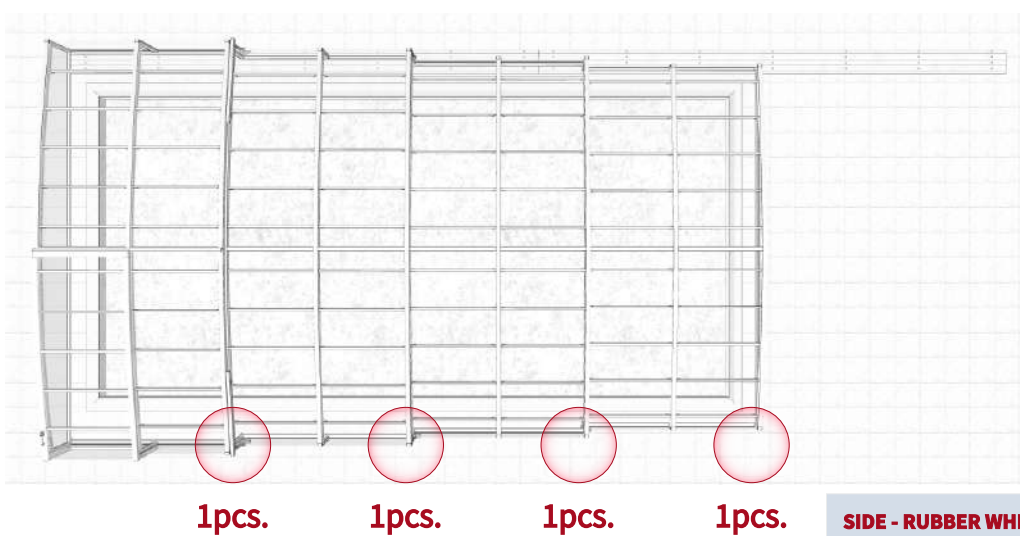

SIDE - RUBBER WHEELS

### THE INDEPENDENT SEGMENTS

**SIDEARRESTMENT - FOR EACH SEGMENT (each ascending segment is overlapping with descending segment)**

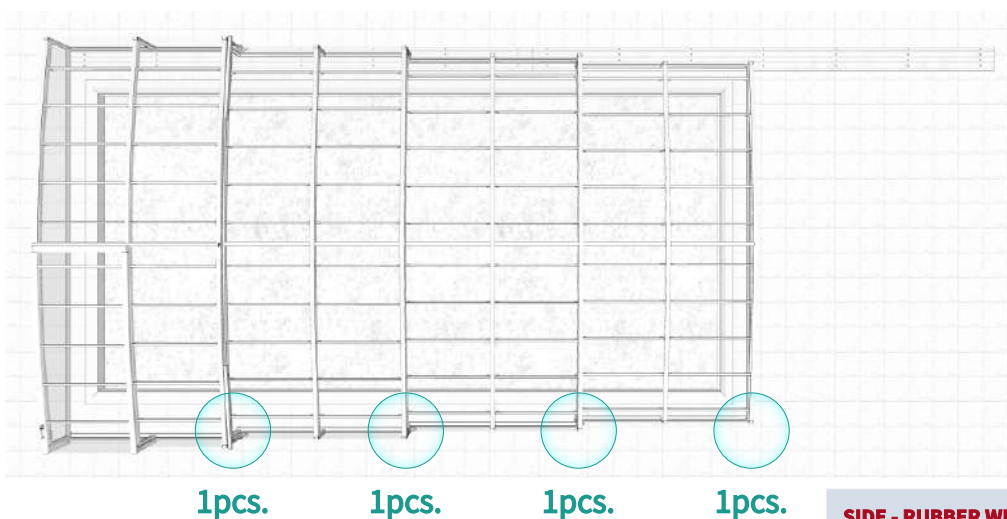

SIDE - RUBBER WHEELS

## SIDE ARRESTMENT - FIX TO CONCRETE



### COMPONENT

**PLASTIC HEADER WITH ROD  
( UPPER PART OF SIDE ARRESTMENT )**

### ALTERNATIVE PART FOR CONCRETE

**PLASTIC INSERT  
( BOTTOM PART OF SIDE ARRESTMENT )**

### MARK A CIRCLE WITH CENTRE CROSS

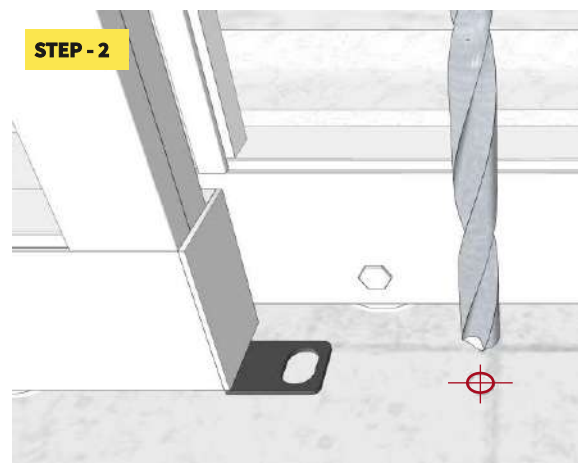
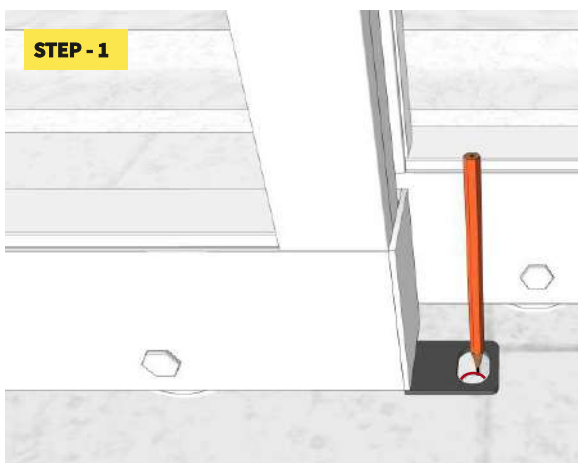
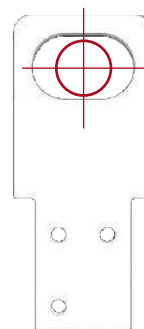

Mark a circle with centre cross for drilling. Mark a circle with a center cross for drilling.

Use drill bit  $\varnothing$  20mm for drilling to concrete - this drilling is suitable if the segments are given aside.

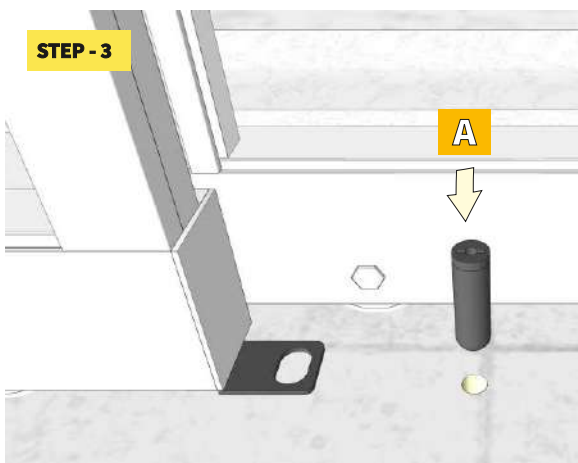

The plastic insert ( bottom part ) put to drilling hole and hammer in into drilling hole.

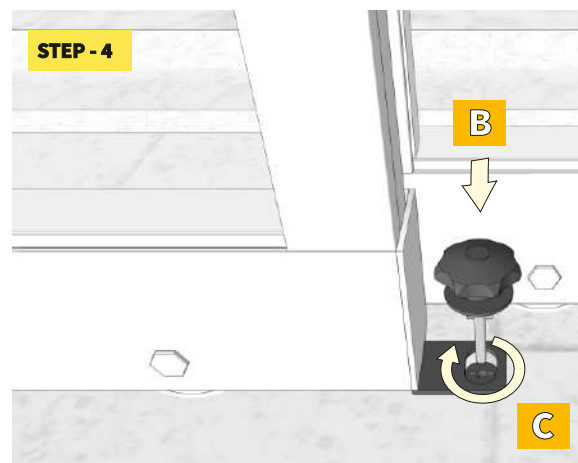

The plastic holder ( upper part ) push down and turn 90° with this for final fix.

## SIDE ARRESTMENT - FIX TO WOODEN FLOOR

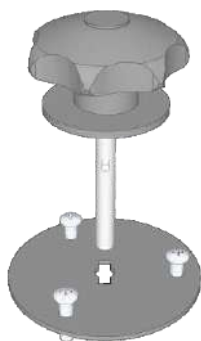

### COMPONENT

**PLASTIC HEADER WITH ROD  
( UPPER PART OF SIDE ARRESTMENT )**

### ALTERNATIVE PART FOR WOODEN FLOOR

**( BOTTOM PART OF SIDE ARRESTMENT  
and some 3 pcs. bolts to wood )**

### MARK A CIRCLE WITH CENTRE CROSS

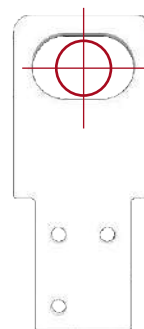

#### STEP - 1

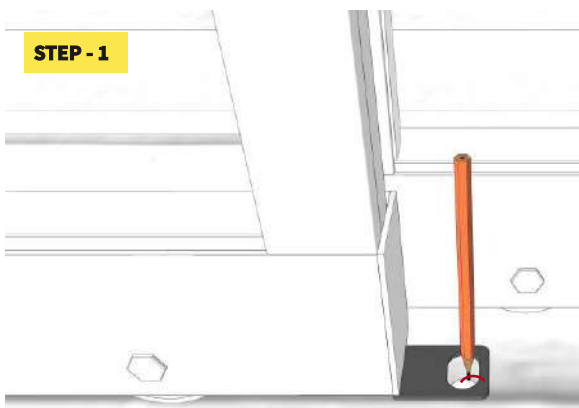

#### STEP - 2

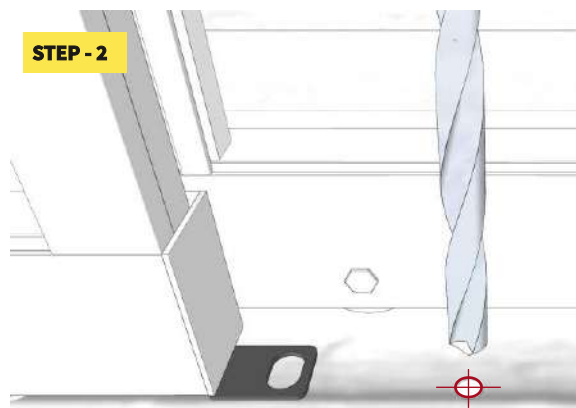

Mark a circle with centre cross for drilling. Mark a circle with a center cross for drilling.

Use drill bit  $\varnothing$  15mm for drilling to wooden floor - this drilling is suitable if the segments are given aside.

#### STEP - 3

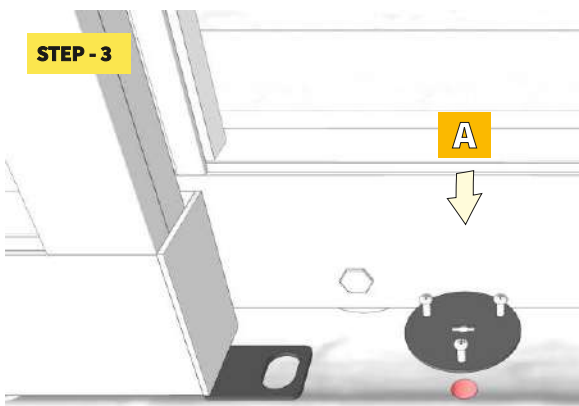

The steel circle insert ( bottom part ) is centered per drilling hole and this insert fix by 3 pcs. bolts to wood.

#### STEP - 4

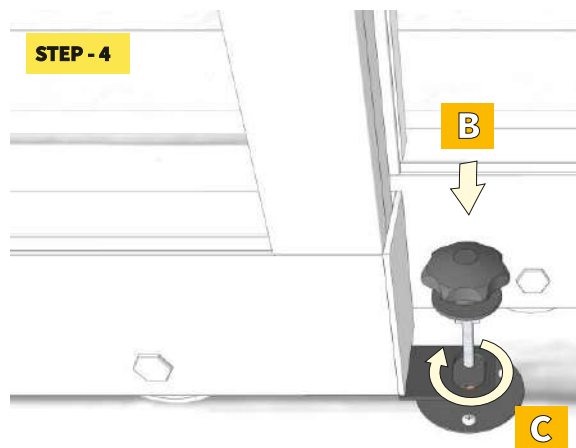

The plastic holder ( upper part ) push down and turn 90° with this for final fix.

## **PLASTIC BACKSTOP FOR SMALLEST SEGMENT**

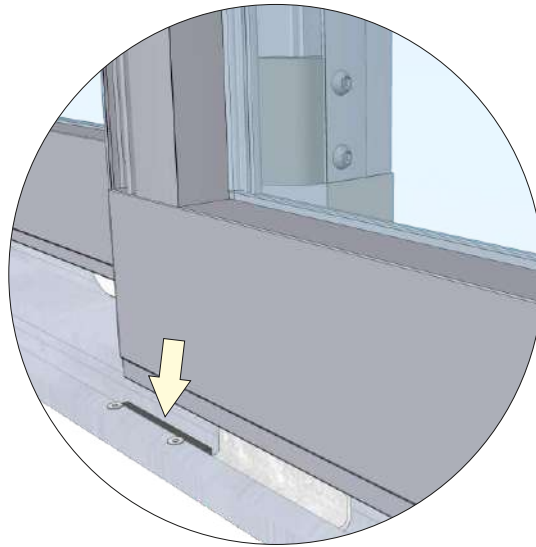

### **THE DEPENDENT SEGMENTS**

***PLASTIC BACKSTOP - FOR SMALLEST SEGMENT ONLY***



### **THE INDEPENDENT SEGMENTS**

***PLASTIC BACKSTOP - HERE NO NEED!***

# ITEM **PLASTIC BACKSTOP**

## PLASTIC BACKSTOP / DEPENDENT SMALLEST SEGMENT

### THE DEPENDENT SEGMENTS

**PLASTIC BACKSTOP - FOR SMALLEST SEGMENT ONLY**

*(this position of plastic backstop according to cover closed, the largest segment must in right position)*

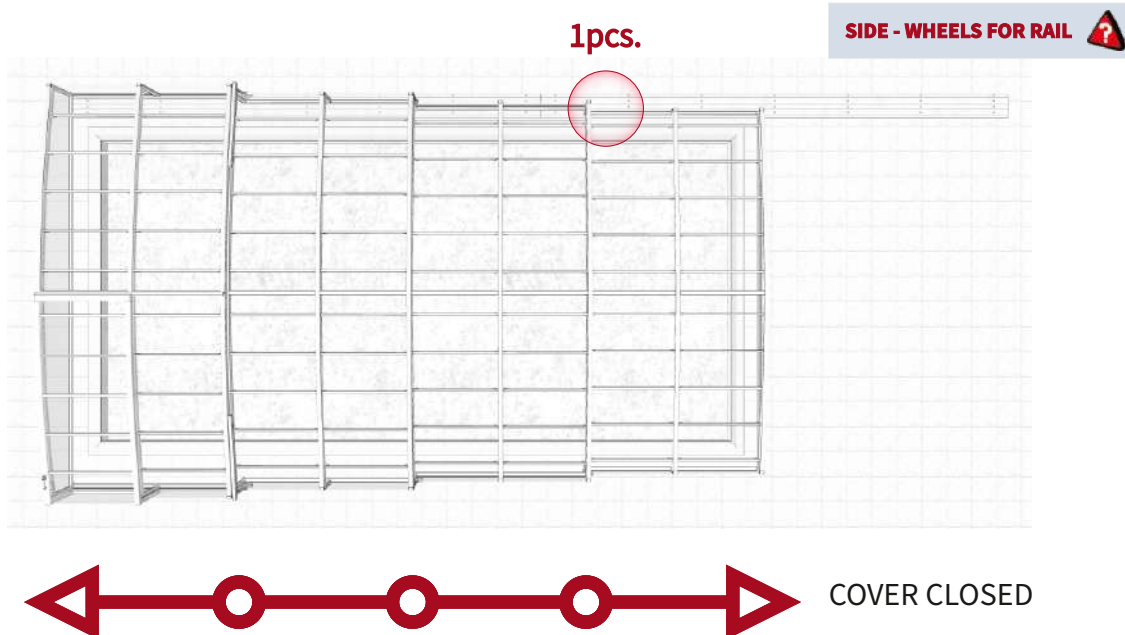

### THE INDEPENDENT SEGMENTS

**PLASTIC BACKSTOP - HERE NO NEED!**

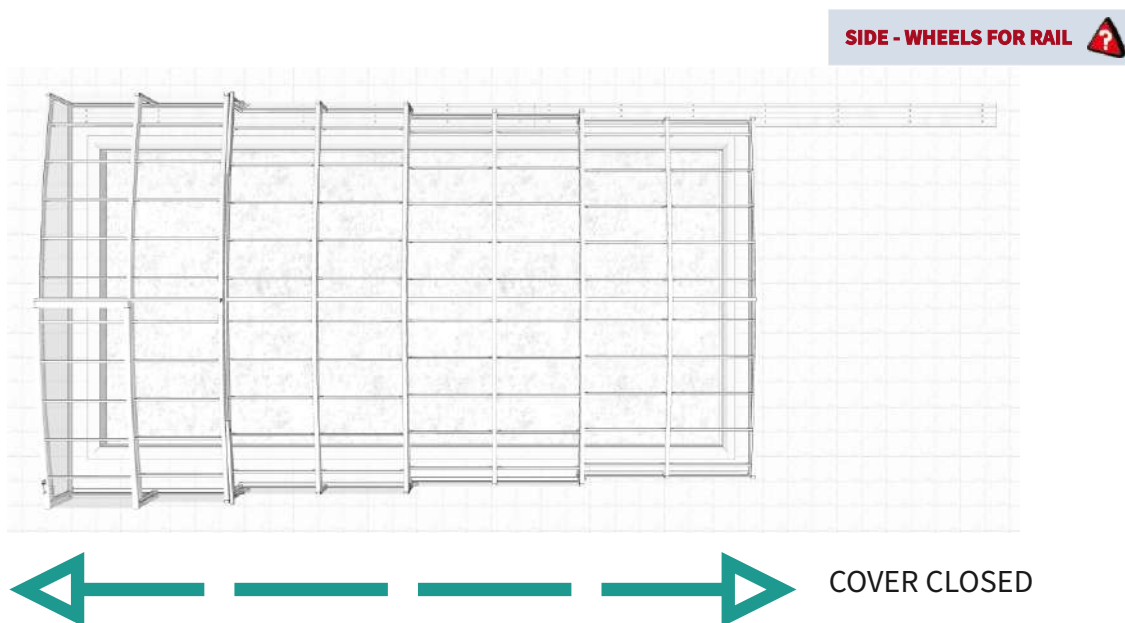

## PLASTIC BACKSTOP - FIX TO RAIL



### COMPONENT

**PLASTIC BACKSTOP (1 pce )  
( FOR STOP OF THE SMALLEST DEPENDENT SEGMENT )**



### FIX MATERIAL

**RIVET 4x10 mm A2 (2 pce )**

### STEP - 1

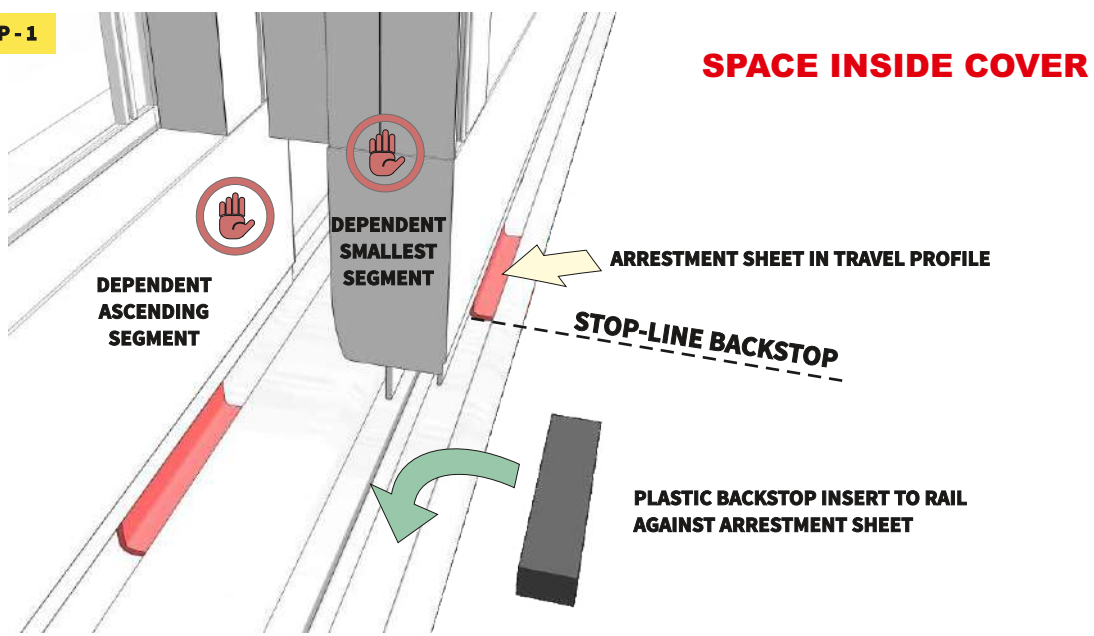

### STEP - 2

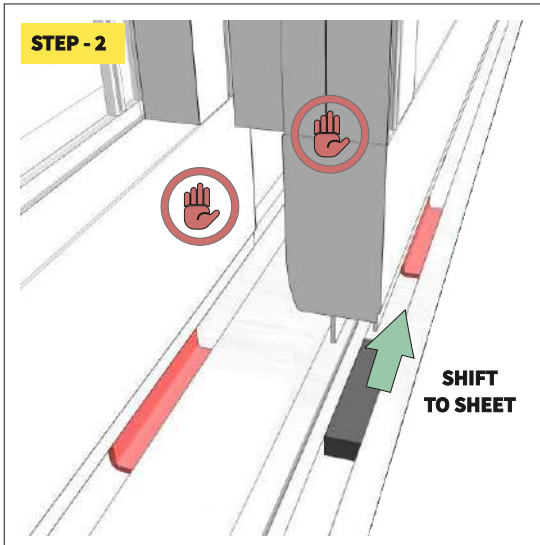

### STEP - 3

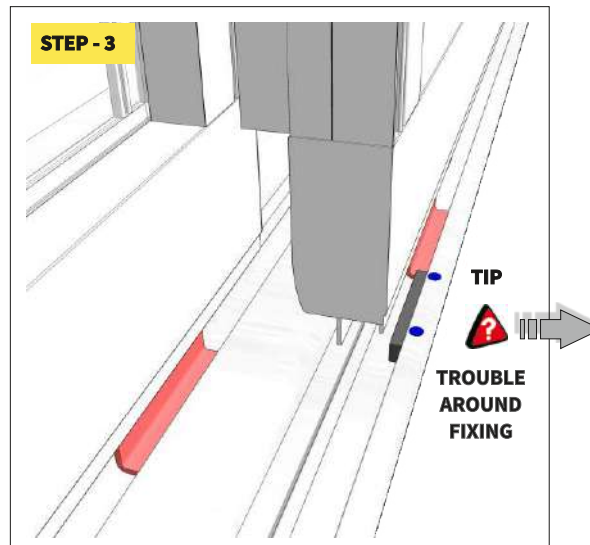

**DETAIL OF TIP  
STEP-1**

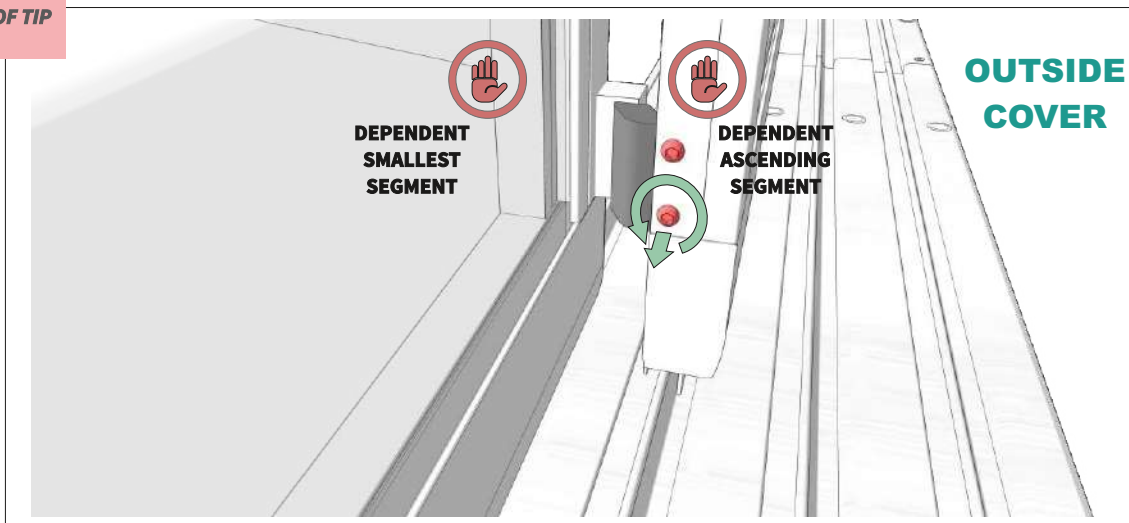

**DETAIL OF TIP  
STEP-2**



**DETAIL OF TIP  
STEP-3**

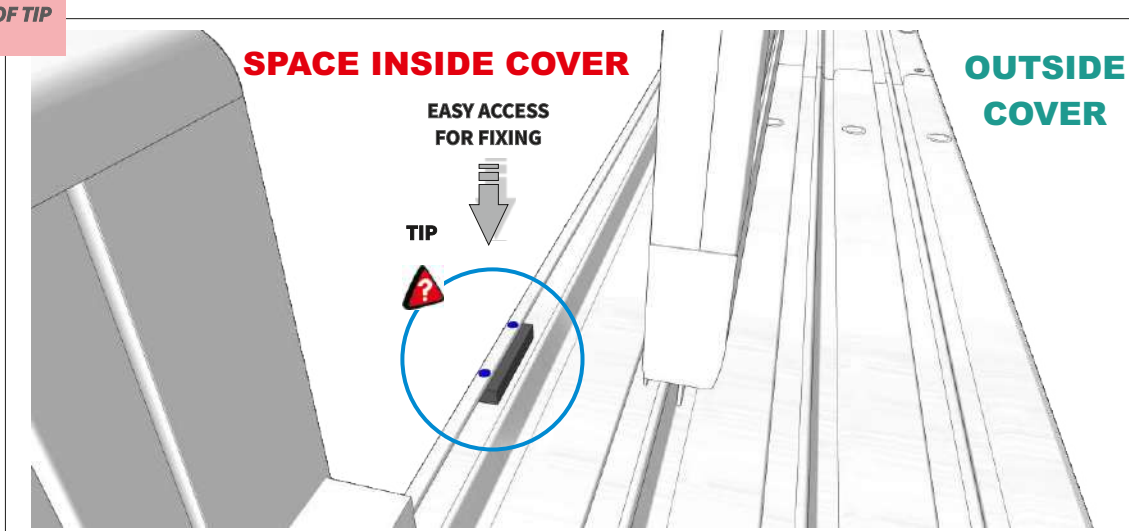

USE OPPOSITE WAY FOR RETURN OF INNER STOPPER TO SEGMENT AFTER FIXING OF PLASTIC BACKSTOP INTO RAIL.

Alukov®

ITEM

# FACE ARRESTMENTS

---

ASSEMBLING INSTRUCTIONS FOR ENCLOSURES

## FACE ARRESTMENT - FIXING TO EACH FACE



**THIS FACE ARRESTMENT ASSEMBLY ONLY ON FACES, WHEN COVER IS CLOSED !**

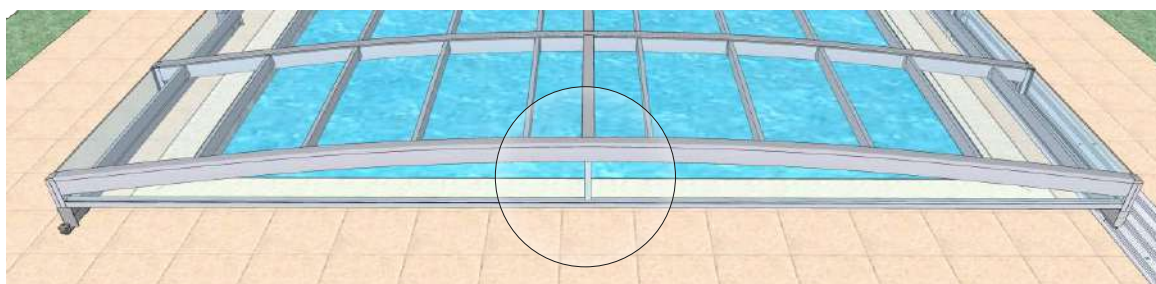
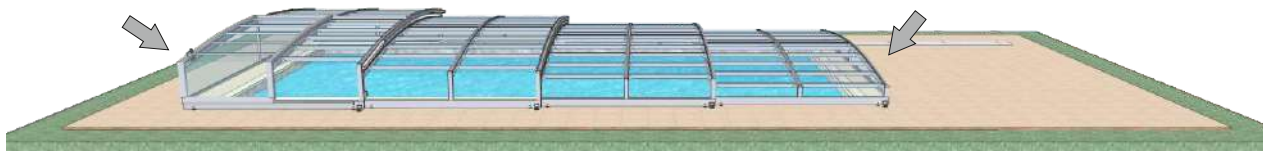

### FIX MATERIAL

#### RIVET 4x10 mm A2

(2 pce for join of one sleeve - face arrestment)



### ARRESTMENT COMPONENTS

*this arrestment components secure the enclosure especially against a climatic influences.*

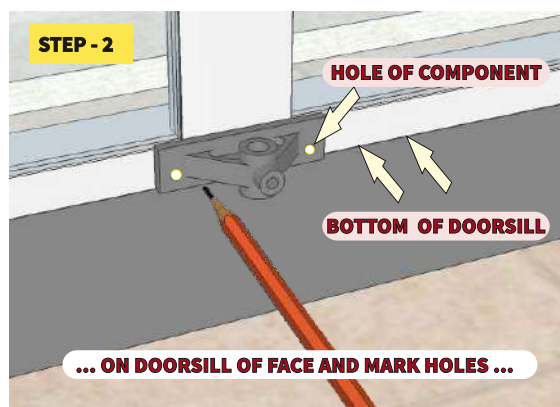
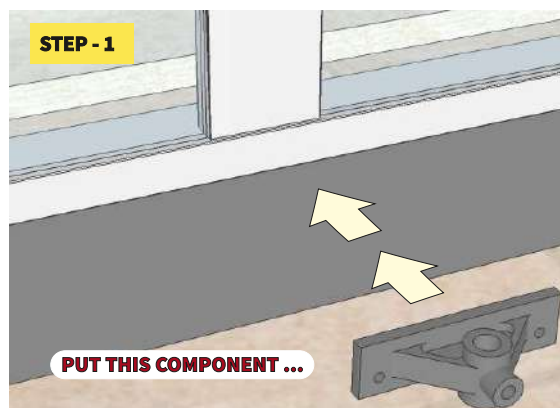

**RISK FOR DAMAGE  
CRACK OF POLYCARBONATE IN FACE !**

**STEP - 2  
HOLE OF COMPONENT MUST BE NEAR OF LOWER  
EDGE OF DOORSILL !**



## INSERT FOR PAVEMENT - DRILLING INTO PAVEMENT OR GROUND



**STEP - 6**  
**CAREFULL DRILLING A HOLE INTO A PAVEMENT OR GROUND !**  
**RISK FOR DAMAGE - CRACK OF PAVEMENT OR GROUND !!!**

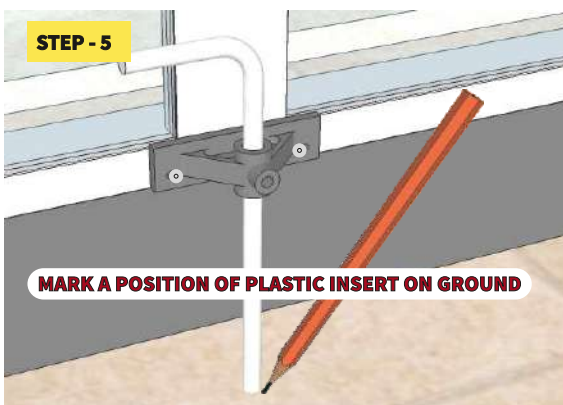

## FACE ARRESTMENT - BASIC FUNCTION

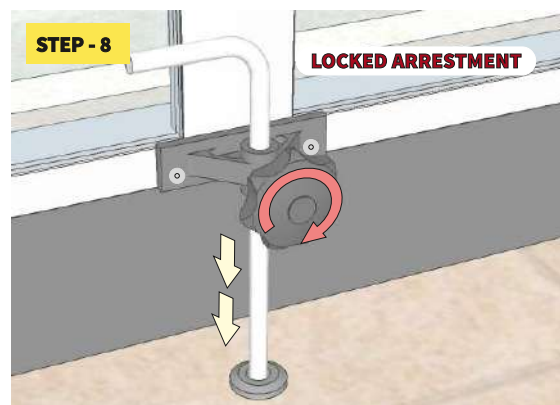

Alukov®

ITEM  
**FINALIZATION**

---

ASSEMBLING INSTRUCTIONS FOR ENCLOSURES

## FINALIZATION



**DETAIL nr.1 - CLEAN ALL PARTS OF THE ENCLOSURE, LEADING LINES INCLUDED.**

**DETAIL nr.2 - CHECK FUNCTIONALITY OF ALL PARTS AND OF ENTIRE ENCLOSURE.**

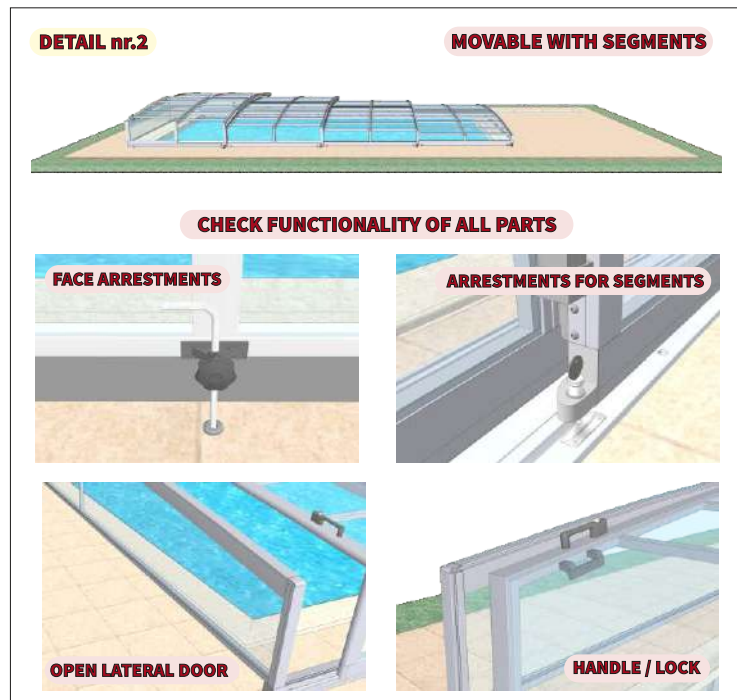

**CLEAN A PLACE OF ASSEMBLING AND RESTORE ALL THE OBSTACLES, WHICH HAD TO BE REMOVED BEFORE THE MANIPULATION WITH SEGMENTS TOO.**

## REMOVE OF THE PROTECTION FOIL FROM ALL POLYCARBONATE



**THE POLYETHYLENE MASKING (PLASTIC SHEETS/FOIL) MUST BE REMOVED IMMEDIATELY FROM THE PANELS DURING OR IMMEDIATELY AFTER INSTALLATION.**

**IF IT IS REMOVED AT A LATER TIME, IT MAY BE VERY DIFFICULT IF NOT IMPOSSIBLE TO REMOVE AS IT WILL STICK TO THE PANEL. IN HOT CLIMATES, EVEN 24 HOURS AFTER THE INSTALLATION IS COMPLETED IT MAY BE TOO LATE TO REMOVE.**

